

duraflo®

ABS PIPE & FITTINGS

DESIGN

VIADUX VERSION 2

ABS PIPE & FITTINGS

DESIGN

DISCLAIMER

This document has been prepared by Viadux to assist qualified engineers and contractors in the selection of the Company's product, and is not intended to be an exhaustive statement on pipeline design, installation or technical matters. Any conclusions, formulae and the like contained in the manual represent best estimates only and may be based on assumptions which, while reasonable may not necessarily be correct for every installation.

Successful installation depends on numerous factors outside the Company's control, in to any person who relies on the whole or any part of this manual and excludes all liability imposed by any statute or by the general law in respect of this manual whether statements and representation in this manual are made negligently or otherwise except to the extent it is prevented by law from so doing. The manual is not an offer to trade and shall not form any part of the trading terms in any transaction. Viadux trading terms contain specific provisions which limit the liability of Viadux to the cost of replacing or repairing any defective product.

COPYRIGHT

This manual is a publication of Viadux Pty Ltd, ABN 75 087 415 745, and must not be copied or reproduced in whole or part without the Company's prior written consent.

This manual is and shall remain as the Company's property and shall be returned to the Company on its request. The Company reserves the right to make changes to any matter at any time without notice.

All Viadux trademarks and logos are owned by Viadux Pty Ltd. All other brand or product names are trademarks or registered marks of their respective owners.

CONTENTS

Introduction	2
Valve Selection Criteria	4
Pipe Design Criteria	5
Pressure Temperature Derating	6
Flow Calculation For Liquids	7-8
Thermal Expansion	9
Designing For Pipe Expansion	10
Expansion Loops	11
Expansion Compensator	12
Rubber Bellows	12
Pipe Wall Stressing	12
Pipe Support	13
Pipe Support Pads	13
Pipe Anchors	14
Support Of Heavy Pipe Line Accessories	15
Equipment Connections	15
Pipe Support Centres	15
Deflecting Pipes On A Curve	15
Collapse Resistance	16

ABS PIPE & FITTINGS DESIGN MANUAL

THE COMPANY

Viadux has a highly trained and experienced team who are dedicated to the design, manufacture, installation and operation of its products.

The company is committed to a program of continuous improvement in the quality and reliability of its products and services. Technical advice is available from our engineer team. Application advice and support is also available.

Our products are manufactured to conform to recognised international engineering quality standard such as Australian Standard AS/NZS 3518. DURAFLO ABS Pipe & Fittings are also accredited to ISO9001:2008 Quality System.

INTRODUCTION

ABS thermoplastics are recognized as a suitable material to be used in many industry applications.

The material is very tough and resilient, has high impact strength, good chemical resistance, non-toxic and taint free.

ABS Piping Systems are replacing many systems made from other materials.

DURAFLO Piping Systems comprises a large range of pressure ratings for pipes and fittings, joined together by cold solvent cement welding.

MATERIAL PROPERTIES

The formulation of ABS used by Viadux has been developed in conjunction with polymer manufacturers to optimise performance in respect to tensile strength, chemical resistance, ductility, resistance to weathering, heat stability, low toxicity, taint free and ease of processing from raw material to finished product.

ABS is tough and strong over the recommended temperature range of -30°C to +60°C.

ABS APPLICATIONS

Our products are widely used in a variety of applications such as:

- HVAC, chilled water and condenser
- Water reticulation
- Domestic plumbing
- Water treatment plants
- Waste water treatment and recycling plants
- Power generation plants
- Industrial plants such as electronics, food processing, chemical, paper mills, palm oils and rubber mills.

THE MATERIAL

Acrylonitrile—Butadiene—Styrene (ABS) identifies a family of engineering thermoplastics with a broad range of performance characteristics. The copolymeric system is alloyed to yield the optimum balance of properties suited to the selected end use.

ACRYLONITRILE—imparts chemical resistance and rigidity.

BUTADIENE—endows the product with impact strength, toughness and abrasion resistance.

STYRENE—contributes to the lustre, ease of processing and rigidity.

ABS HAS OUTSTANDING PROPERTIES

- High impact strength and ductility, which combine to give exceptional toughness
- Good chemical resistance
- Abrasion resistance
- High strength, solvent weld jointing which allows efficient system assembly and modification
- Withstands aggressive ground waters
- High strain tolerance for buried applications
- Good resistance to ultraviolet light
- Better flow rate

PRESSURE RATINGS

DURAFLO ABS Piping Systems are available in a range of sizes from DN 15 to DN 750. Standard pressure ratings at 20°C are 900kPa, 1200kPa and 1500kPa (Class C, Class D and Class E).

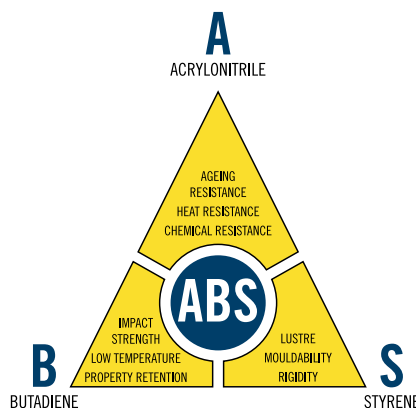

ABS PIPE & FITTINGS DESIGN MANUAL

ENVIRONMENTAL

The use of ABS contributes positively to the environment as it takes approximately one sixth of the energy to manufacture compared to metal products. This has direct savings in greenhouse gas emissions. Additionally ABS is lead and chlorine free and can be readily recycled.

IMPACT STRENGTH

The butadiene constituent in ABS affords unrivalled resistance to impact. This means that DURAFLO Piping systems may be used in more critical applications where other types of plastics could not be considered.

ABS is a ductile material and the mode of failure resembles that of soft copper. Failure is by ductile distortion and tearing, the localized nature minimizing the loss of pipe contents.

In contrast, crack propagation and hazardous material fragmentation accompany the failure of brittle material.

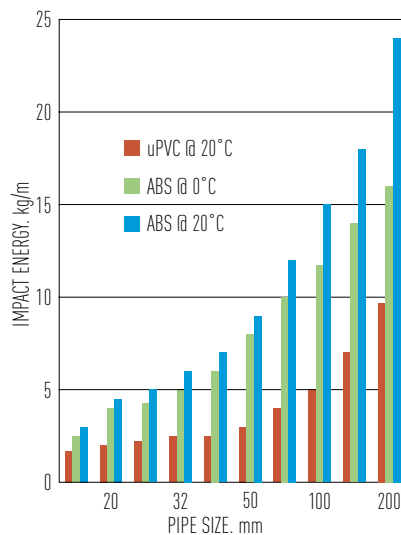

ABRASION RESISTANCE

DURAFLO ABS offers outstanding resistance to abrasion and erosion from aggressive slurries which can rapidly damage steel or other traditional pipe materials.

WEATHER RESISTANCE

DURAFLO ABS displays good weather resistance. Successful field tests have been completed on piping systems having been exposed to weathering for over 30 years.

LIGHT WEIGHT

ABS is one-sixth the weight of steel systems, making DURAFLO easy to handle and install. This reduces the cost of installation, handling and transport.

CHEMICAL RESISTANCE

DURAFLO ABS is unaffected by both internal and external attack by a wide range of acids, alkalis, ground water salts and other environmental factors. Please refer to Viadux for further information.

QUICK REFERENCE CHEMICAL RESISTANCE

Weak acids	Good resistance
Strong acids	Limited resistance
Weak alkalis	Good resistance
Strong alkalis	Good resistance
Aggressive soils	Excellent resistance
Metal salts	Good resistance
Sea water	Excellent resistance
Aromatic hydrocarbons	Poor resistance
- Organic solvents	Poor resistance

NON-TOXIC / TAINT FREE

The ABS formulation contains no harmful metallic stabilisers and it has been widely used for many years in piping systems for drinking water, medical preparations, food products and potable water. DURAFLO ABS Systems are ideal for potable cold water. They conform to AS 4020 requirement for potable water reticulation and distribution.

SMOOTH BORE

DURAFLO ABS does not suffer from internal corrosion and provides a smooth bore for the life of the piping systems. The smooth bore does not support formation of scale and slime as with cement based lined products.

COLD SOLVENT WELD JOINING

The DURAFLO range also utilises the proven traditional method of joining ABS pipes, cold solvent cement welding. This provides a homogeneous bond between pipes and fittings (SWJ).

TEMPERATURE RANGE

A great advantage of DURAFLO ABS over other plastic systems is its ability to perform over a wide temperature range from -30°C to +60°C. This makes DURAFLO ABS very versatile and capable of handling a wide variety of fluids from refrigerants to moderately hot corrosive liquids.

THERMAL EXPANSION

All thermoplastics expand at a greater rate than metal.

Expansion need not cause undue concern in design or installation of an ABS piping system provided that due recognition is taken at the design stage. The reduced flexural modulus of ABS over that of steel results in reduced loads on supports and equipment arising from thermal strains. The linear coefficient of thermal expansion of ABS is $10.1 \times 10^{-5} \text{m/m}^\circ\text{C}$.

ABS PIPE & FITTINGS DESIGN MANUAL

VALVE SELECTION CRITERIA

This table will assist with the selection of suitable thermoplastic valves.



	BALL	DIAPHRAGM	BUTTERFLY
Size range	DN 15 - DN 100	DN 15 - DN 50	DN 50 - DN 200
Clean liquid	Good	Good	Good
Slurry	Refer to Viadux	Suitable	Refer to Viadux
Flow control	Off / On	Good	Moderate
Position indicator	Yes	Yes	Yes
Vacuum proof	Yes	No	Yes
Pressure surge behaviour	Good	Refer to Viadux	Good
Sealing materials	FPM / PTFE EDPM / PTFE	Natural rubber Butyl rubber PTFE / EDPM	FPM EDPM
Maximum pressure range @ +20°C	1600kPa	1000kPa	1000kPa
Suitable for electric or pneumatic actuator	Yes	Yes	Yes
End connection	Socket, thread, flange	Spigot, socket, thread, flange	Wafer style



ABS PIPE & FITTINGS DESIGN MANUAL

PIPE DESIGN CRITERIA

DURAFLO pipe design is in accordance with the requirements set out in AS/NZ3518.

DESIGN FACTOR OF SAFETY (F)

This factor is applied to the minimum ultimate strength of material to establish 'safe' (conservative) working loads.

The DURAFLO standard range of pipes is engineered using a minimum design safety factor of 1.6. This degree of safety margin in the design of pipes means that the standard DURAFLO range of pipes are suitable for application in critical services such as permanent urban water supply applications and where high security is required for the transport of hazardous chemicals.

DESIGN BASIS

This is a period, usually a minimum of 50 years according to convention, which is used to determine the long term hydrostatic strength of ABS pipe.

HYDROSTATIC DESIGN STRESS

This hydrostatic design stress (HDS) is the minimum required strength (MRS) divided by the Design Safety Factor.

For the minimum design safety of 1.6 used in the DURAFLO pipe ranges, the maximum HDS of 10 MPa is used.

LONG TERM HYDROSTATIC STRENGTH

This is the 97.5% lower confidence limit value of hoop stress, continuously applied at a specified temperature that



the pipe wall material can support for a specified time.

This value is calculated using the statistical procedures detailed in the standard extrapolation method of ISO/TR 9080.

MINIMUM REQUIRED STRENGTH (MRS)

This is the minimum value of ΔLCL for a temperature of 20°C and for the conventional period of 50 years. The ABS material used to manufacture DURAFLO ABS has an MRS of 16MPa.

PN VALUE

This is the nominal working pressure at 20°C, in bar (10 bar = 1 MPa).

STRESS REGRESSION

At a constant temperature the time to failure due to stress of a thermoplastic pipe is inversely proportional to the magnitude of the stress.

By conducting a series of burst tests on ABS material at different stress levels, a graph of stress versus time to fracture can be plotted. This is always shown as a log-log plot and is known as the Stress Regression Characteristic for the pipe. It is representing a possible 'life' for the pipe manufactured from the selected ABS raw material compound.



ABS PIPE & FITTINGS DESIGN MANUAL

PRESSURE/TEMPERATURE DERATING

All thermoplastic piping system pressure ratings apply at the standard mid-wall temperature of 20°C. Where systems are required to operate at higher continuous mid-wall temperatures, pressure ratings must be adjusted in accordance with the following graph. The pressure values from 10°C up to 50°C are for 50 years design life, for 60°C are for 20 years design life.

OPERATING PRESSURE BASED ON TEMPERATURE RERATING

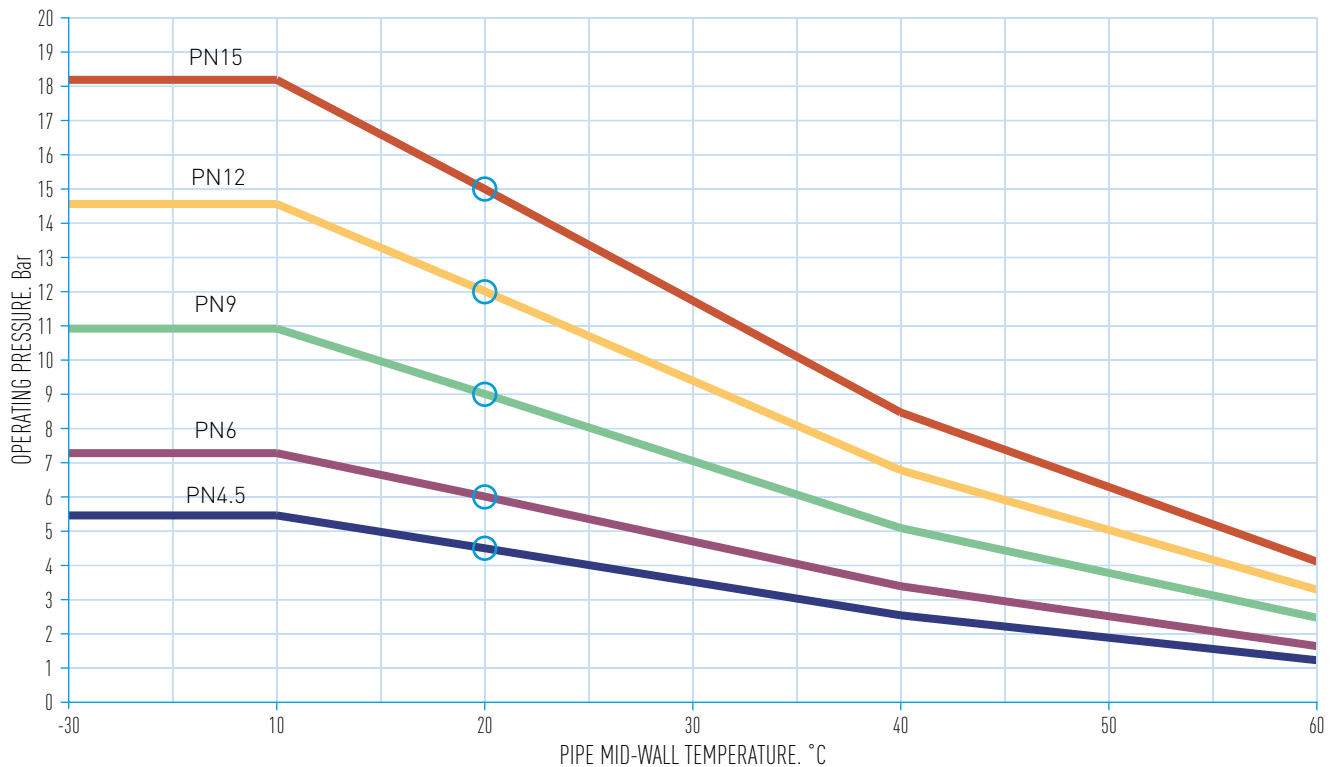

ABS PIPE & FITTINGS DESIGN MANUAL

FLOW CALCULATIONS FOR LIQUIDS

The extreme smoothness of the DURAFLO ABS pipe and the chemical resistance of the material to water prevents internal corrosion. Consequently, the hydraulic characteristics of an ABS DURAFLO pipe generally remain constant for the life of the system. DURAFLO ABS pipes do not need to be "over-sized" in the design stage to allow for future performance losses due to corrosion.

For gravity pipe systems where the flow regime may be partially full, the engineer should refer to the procedure in AS 2200 - Design charts for water supply and sewerage.

PRESSURE LOSS CALCULATION PROCEDURE

Pressure drops due to friction may be determined for practical purposes using nomograms (flow charts). Full range of nomograms for applications where the media is water can be found at the end of this catalogue. (Absolute roughness for ABS pipe in operation, $\epsilon = 0.007\text{mm}$).

The fluid pressure loss through fittings may be included in the overall system pressure loss by calculating the equivalent length of pipe equal to the pressure loss through individual fittings.

The calculations of pressure loss in fittings is:

$$E_f = F \times D$$

where:

E_f = equivalent length of straight pipe for fittings. m

F = fittings constant (see adjacent column)

D = fittings diameter, mm

To calculate the total pressure loss in the system, the equivalent straight pipe length for fittings is added to the total measured straight pipe length.



ALTERNATIVE PROCEDURE

The aforementioned method will provide a conservative selection of pipe diameter and class for an application. A more rigorous approach will derive significant savings in the design of a pipe system.

ABS FITTINGS CONSTANTS

Fittings	F
Elbow 90	0.017
Elbow 45	0.009
Bend 90° Short Radius	0.004
Bend 45° Short Radius	0.002
Bend 90° Long Radius	0.002
Bend 45° Long Radius	0.001
Tee Through	0.011
Tee Branch	0.042

LOSS IN STRAIGHT LENGTHS OF PIPE

The head loss in straight lengths of pipe can be calculated as follows :

$$H_p = f \frac{L}{d} \times \frac{v^2}{2g}$$

where

L = length of pipe. m

H_p = head loss. m

f = Darcy friction factor, dimensionless

d = inside diameter of pipe. m

v = mean velocity of media. m/s

$g = 9.81\text{m/s}^2$,
acceleration due to gravity

The Darcy friction factor is dependent upon the Reynolds number, Re , and the relative roughness of the pipe surface,

$$\frac{\epsilon}{d}$$

where

ρ = density. kg/m^3

μ = dynamic viscosity. kg/m/s

ϵ = absolute roughness. mm

$\epsilon = 0.003\text{mm}$, the absolute roughness for clean ABS

ABS PIPE & FITTINGS DESIGN MANUAL

COEFFICIENT OF FRICTION FOR FITTINGS. K_f

Type of Fitting	K_f
Elbows	
90°	1.2
45°	0.35
Bends—Sweep	
90°	0.5
45°	0.2
22°	0.1
Tees	
Flow through	0.6
Flow to branch	1.8
Flow from branch	1.5
Entries	
Square	0.65
Protruding	0.75
Slightly rounded	0.21
Bellmouth	0.06
Outlets (all)	
1.0	
Sudden Enlargements	
Inlet to outlet ratio 4:5	0.15
Inlet to outlet ratio 3:5	0.4
Inlet to outlet ratio 1.2	0.6
Inlet to outlet ratio 2:5	0.75
Inlet to outlet ratio 1:5	0.9
Sudden Contractions	
Inlet to outlet ratio 4:5	0.45
Inlet to outlet ratio 3:5	0.38
Inlet to outlet ratio 1.2	0.35
Inlet to outlet ratio 2:5	0.28
Inlet to outlet ratio 1:5	0.15
Valves Fully Open	
Gate	0.2
Butterfly	0.3
Ball	0.5
Swing check	1.3
Diaphragm	2.4

LAMINAR FLOW. In this type of flow $Re < 2000$ and the Darcy factor yields:

$$f = \frac{64}{Re}$$

TURBULENT FLOW. The friction factor for $Re > 2000$ is calculated using the Colebrook White equation:

$$\frac{1}{\sqrt{f}} = -2 \log_{10} \left(\frac{\epsilon}{d} + \frac{2.51}{Re \sqrt{f}} \right)$$

HEAD LOSS IN FITTINGS

$$H_f = \sum K_f \times \frac{v^2}{2g}$$

where

$$\sum K_f = N_{\text{bends}} K_{\text{bends}} + N_{\text{elbows}} K_{\text{elbows}} + N_{\text{tees}} K_{\text{tees}} + \dots$$

where

K_f = coefficient of friction for each type of fitting, shown in the adjacent table

N = number of fittings of each type

TOTAL HEAD LOSS

Using the head loss calculations above, the pressure drop in the pipeline is calculated using the formula:

$$\Delta p = \rho g (H_p + H_f), \text{ N/m}^2$$

Notes.

- The Reynolds number range between 2000 and 4000 is called the critical zone. Flow in this zone is unstable, and this must be taken into account.
- The methods shown above can be used with various types of Newtonian fluids.

ABS PIPE & FITTINGS DESIGN MANUAL

THERMAL EXPANSION

Expansion is not a problem during the installation of an ABS DURAFLO pipe systems provided the appropriate provisions are made during the design stage.

The linear coefficient of thermal expansion for DURAFLO ABS Pipe is $10.1 \times 10^{-5} \text{m/m}^\circ\text{C}$ ($5.6 \times 10^{-5} \text{ft/ft}^\circ\text{F}$).

The variation in pipe wall temperature should be used in the following equation to calculate the maximum pipe thermal movement. (Pipe operating and shut down conditions should be considered when evaluating extreme temperature variations).

$$\Delta L = L \times C \times \Delta T$$

where

ΔL = pipe expansion/contraction. m

L = original pipe length. m

C = linear coefficient of thermal expansion. $10.1 \times 10^{-5} \text{m/m}^\circ\text{C}$

ΔT = pipe wall temperature variation. $^\circ\text{C}$

The mid-wall temperature is dependent on the internal and external environmental temperatures with the temperature of the flowing media having the greater influence.

The variation in pipe wall temperature can be calculated as :

$$\Delta T = 0.65\Delta T_L + 0.10\Delta T_A$$

where

ΔT = pipe wall temperature variation. $^\circ\text{C}$

ΔT_L = maximum temperature variation in pipe content. $^\circ\text{C}$

ΔT_A = maximum temperature variation of external air. $^\circ\text{C}$

EXAMPLE

Calculate the thermal expansion of a 50 metre section of DURAFLO ABS Pipe with an expected variation in the temperature of the fluid conveyed from 20°C to 30°C and an expected variation of the ambient temperature from 10°C to 40°C .

$$\Delta T_L = 30 - 20 = 10^\circ$$

$$\Delta T_A = 40 - 10 = 30^\circ\text{C}$$

$$\Delta T = 0.65\Delta T_L + 0.10\Delta T_A = 6.5 + 3 = 9.5^\circ\text{C}$$

$$\Delta L = L \times C \times \Delta T$$

$$\Delta L = 50 \times 10.1 \times 10^{-5} \times 9.5 = 0.047975\text{m}$$

$$\Delta L = 47.98\text{mm}$$

The following graph allows you to read directly total pipe expansion from a known pipe length and temperature range.

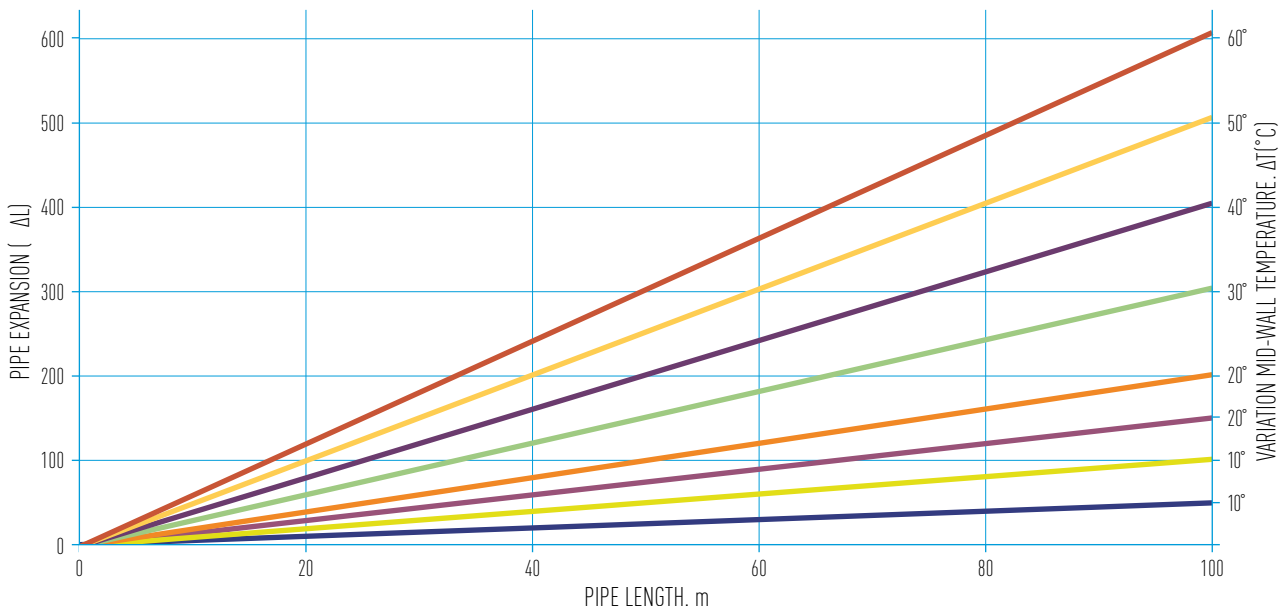

ABS PIPE & FITTINGS DESIGN MANUAL

DESIGNING FOR PIPE EXPANSION - ABOVE GROUND

Pipe expansion of a cold solvent cement welded pipeline may be accommodated using any one or combination of the following techniques:

- Pipe route planning
- Expansion loops
- Expansion joints (rubber bellows)
- Pipe wall stressing

PIPE ROUTE PLANNING

In the vast majority of cases, effective route planning can eliminate the requirement of expansion loops, or expansion bellows, etc, with consequent financial savings.

The basic principle of design is to allow pipe runs to move axially from a fixed point (anchor) and then guide this movement into a change of pipe direction ensuring that the pipe is free to flex as shown in figure 1.

FIGURE 1

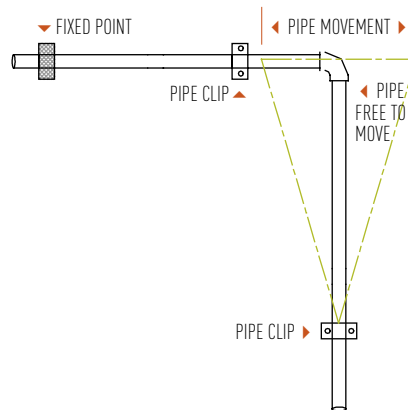

An inappropriate installation is shown in figure 2. The pipe run is fixed at one end **A** and constrained at the other **B**.

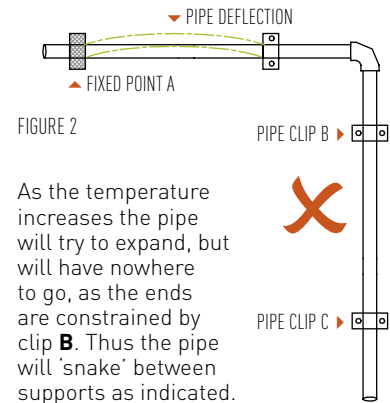

FIGURE 2

As the temperature increases the pipe will try to expand, but will have nowhere to go, as the ends are constrained by clip **B**. Thus the pipe will 'snake' between supports as indicated.

In figure 3, effective route leg planning has eliminated the need for expansion loops, etc, by a simple redesign of pipe supports.

By utilising a suitable pipe support to allow free lateral pipe movement, the pipe can be installed with sufficient flexibility to expand and contract.

The support at **C** remains but the clip at pipe support **B** is eliminated to give sufficient length for flexibility.

FIGURE 3

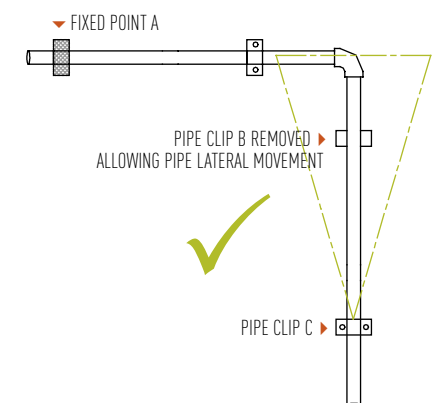

ABS PIPE & FITTINGS DESIGN MANUAL

DESIGNING FOR PIPE EXPANSION - ABOVE GROUND

CALCULATE THE EXPANSION

Establish an anchor point midway along the straight length of pipe to control the direction of any movement.

- Position pipe supports away from change of direction to allow required movement.
- The extent of movement to be accommodated at each end from the neutral position will be + 25% of the total expansion. Example, if total calculated expansion is 100mm, 50mm of this is to be accommodated at each end, which is +25mm from the neutral position, see figure 5.

EXPANSION LOOPS - ABOVE GROUND

Length of the expansion loop legs **H** for sizes up to DN 400 can be determined using the adjacent table. Please refer to Viadux for further information.

The expansion loop table can also be used for calculating flexibility required at changes in direction.

Expansion loop dimensions can be reduced considerably by the use of tandem bellows. Refer Viadux for details.



EXPANSION LOOP LEG LENGTH. H mm

Pipe Size DN	Expansion - $\Delta L/2$ (figure 4) - ΔL (figure 5) mm					
	25	50	75	100	150	200
15	650	920	1130	1300	1595	1840
20	730	1030	1265	1460	1785	2065
25	815	1155	1415	1635	2000	2310
32	915	1300	1590	1835	2250	2595
40	980	1390	1700	1960	2400	2775
50	1095	1550	1900	2200	2690	3105
65	1225	1735	2125	2450	3005	3470
80	1330	1885	2310	2665	3260	3765
100	1510	2135	2615	3020	3700	4270
125	1675	2365	2900	3345	4100	4730
150	1835	2590	3175	3665	4490	5185
200	2120	3000	3675	4240	5195	6000
225	2500	3535	4330	4995	6120	7065
250	2645	3740	4580	5290	6475	7480
300	2805	3965	4860	5610	6870	7930
350	2980	4210	5155	5955	7290	8420
375	3160	4470	5475	6320	7740	8940

FIGURE 4

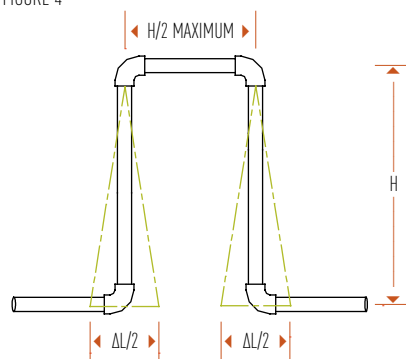
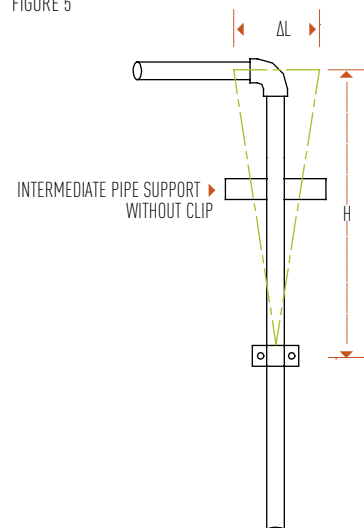

FIGURE 5



ABS PIPE & FITTINGS DESIGN MANUAL

EXPANSION COMPENSATORS

Where space does not permit a flexible route, or the use of expansion loops, rubber bellows should be considered.

EXPANSION COMPENSATOR OPERATING RANGE*

Pipe Size DN	Travel		
	Axial Compression/ Extension mm	Lateral Deflection mm	Angular Deflection
32	8 - 4	8	15°
40	8 - 4	8	15°
50	8 - 5	8	15°
65	8 - 6	10	15°
80	12 - 6	10	15°
100	18 - 10	12	15°
125	18 - 10	12	15°
150	18 - 10	12	15°
200	25 - 14	22	15°
225	25 - 14	22	15°
250	25 - 14	22	15°
300	25 - 14	22	15°
350	25 - 14	22	15°
375	25 - 14	22	15°
400	25 - 14	22	15°
500	25 - 14	22	15°
575	25 - 16	19	15°
650	25 - 16	19	10°
750	25 - 16	19	10°

*Values shown are for the single sphere bellows



GUIDE TO EXPANSION UNIT SELECTION

	Bellows	Dual Bellow Loop	Loop
Accommodate Angular/Lateral Movement	Yes	Yes	Yes
Vibration Isolation	Good	Very good	Moderate
Axial Expansion Range	Very small	Very high	Good
Installation Space	Small	High	Large
Maintenance	Minimum	Minimum	Minimum
Pressure Rating	High	High	High
Size range, DN	32 - 750	300 - 750	32 - 750
Cost/mm Expansion	High	Moderate	High

RUBBER BELLOWS

Rubber bellows are able to accommodate angular, lateral and small axial movements.

Bellows should be located in adjacent pipe legs to benefit from the lateral movement.

Bellows in pressure service should be 'tied' to prevent excessive forces being applied to anchors, nozzles or structures. Tandem bellows can be used to meet large thermal movements.

PIPE WALL STRESSING

In many cases expansion may be taken up by variations in pipe wall stresses. Contact Viadux for further detailed design procedures should this method be adopted.

ABS PIPE & FITTINGS DESIGN MANUAL

PIPE SUPPORT

The basic principle of correct pipe supporting is to allow controlled axial movement of the pipe whilst providing lateral restraint and adequate support for the pipe.

The hanger type support does not provide lateral restraint to the pipe and therefore encourages snaking and so should be avoided except where located adjacent to the changes in direction where flexibility may be required.

Thus pipe supports should:

- Be rigid in construction to adequately support pipe—fabricated mild steel angle being ideal
- Have a wide bearing area—to allow pipe to move easily over support
- Resist deflection—thus transferring loads to the structure
- Be free from sharp burrs or edges to avoid cutting or damaging pipe wall
- Allow controlled axial movement of the pipe
- Provide lateral restraint, where required

Pipe clips should:

- Allow controlled axial pipe movement
- Be free from burrs or sharp edges
- Provide required lateral restraint
- All clips shall be corrosion resistant
- Pipe clips, other than anchor clips shall be so constructed that, when they are securely fixed, longitudinal movement of the pipe is permitted
- Anchor clips for fixed points shall be constructed so that when they are tightened, the fitting or pipe is securely and evenly clamped to prevent movement. The bearing width shall be 25 mm minimum
- Metal clips shall be used in conjunction with resilient material to protect the pipe and shall have a finished clearance across the diameter to allow for radial and longitudinal movement. All materials shall be compatible with ABS, be smooth and free from protrusions.

Viadux provides a range of suitable pipe clips for pipe sizes up to DN 200. For sizes DN 225 and above fabricated mild steel clips with a radial clearance as per the following table are suitable.



Pipe Diameter	Minimum Clearance
Up to DN 150	2 mm
DN 200 - DN 450	5 mm
DN 500 - DN 750	10 mm

PIPE SUPPORT PADS

The use of pipe support pads between pipe and support is strongly recommended where there is likely to be considerable movement of the pipe or chafing of the pipe from vibration. High density polyethylene sheet 6 - 10 mm is suitable for this purpose and should be installed as indicated in figure 6.

Width of pipe supports must be sufficient to allow free axial movement of the pipe without binding.

The following table gives recommended pipe support widths.

Pipe Diameter	Minimum support width
Up to DN300	25 mm
DN350 - DN375	60mm
DN400 - DN450	100 mm
DN500 - DN750	300 mm

FIGURE 6

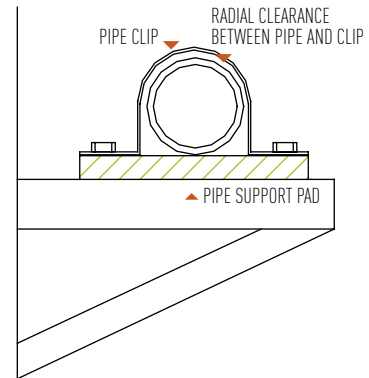

ABS PIPE & FITTINGS DESIGN MANUAL

PIPE ANCHORS

Pipe anchors should be provided in systems where thermal expansion occurs.

Anchors ensure that pipe movement occurs in a controlled and predictable manner.

In addition, pipe anchors will absorb axial pipe pressure thrust in those systems fitted with expansion joints.

Where possible, a flanged pipe connection may be used as an anchor point by the use of a valve support in lieu of one of the backing rings. Refer to figure.7.

Where suitable flange connections are not convenient, pipe anchors may be constructed by solvent cementing split fittings to pipe as shown in figure.8.

An alternative method for pipe diameters up to 50mm is shown in figure.9.

Anchor points located at mid length of a straight section need not be as robust as those associated with expansion compensators which must be able to withstand the total pressure thrust plus frictional resistance to movement.

NOTE: UNDER NO CIRCUMSTANCES SHOULD A TIGHTENED PIPE CLIP BE USED AS AN ANCHOR.

THE ACTION OF TIGHTENING THE CLIP IMPOSES A CRUSHING LOAD ON THE PIPE WHICH MAY DAMAGE THE PIPE AND AFFECT ITS STRUCTURAL STABILITY.

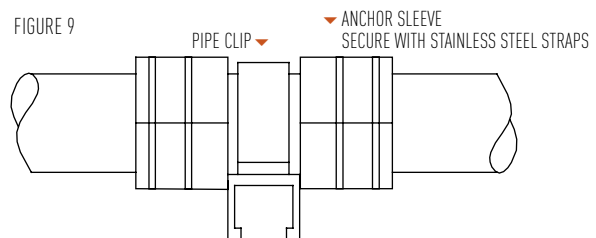
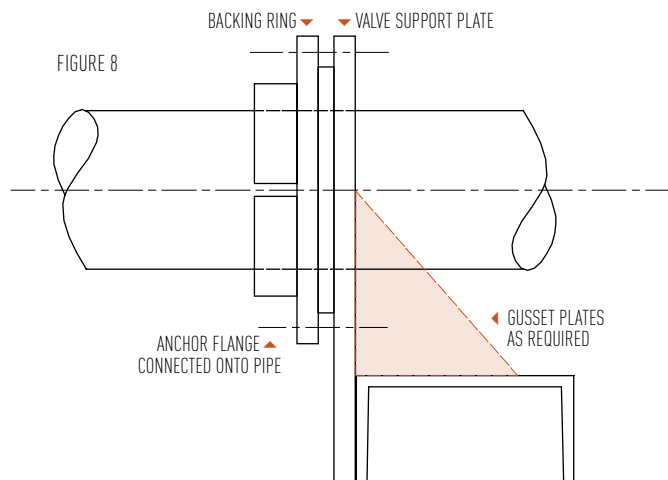
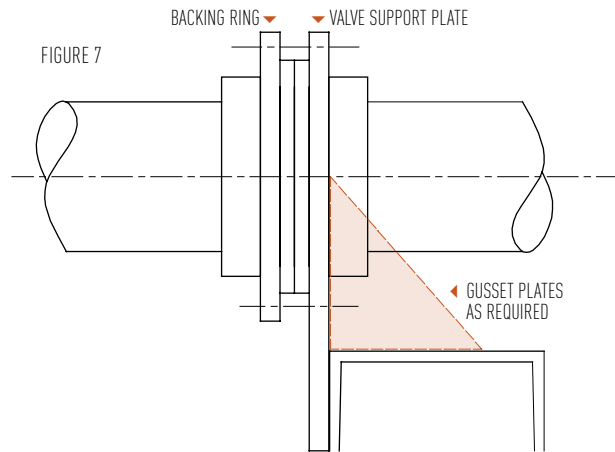

ALTERNATIVE PIPE ANCHOR DETAIL

ABS PIPE & FITTINGS DESIGN MANUAL

SUPPORT OF HEAVY PIPELINE ACCESSORIES

Valves, filters, or other heavy items should always be independently supported or anchored to prevent undue loading and stress being applied to the pipe. DURAFLO valve support plates can be used in place of flange backing rings to provide necessary support.

EQUIPMENT CONNECTIONS

ABS pipe may be connected directly to pipe or other equipment using flanges or threaded connections. Flanges are the recommended method for all sizes, however threaded connections may be used for sizes 50mm or below, refer to the DURAFLO Installation Manual for threaded connection.

PIPE SUPPORT CENTRES

ABS is classified as a strong thermoplastic over its working temperature range of -30° to +60°C.

With increasing temperature, pipe stiffness decreases requiring more frequent support.

The spacing of supports shall be such that the midspan deflection does not exceed 1/500th of the span.

As a guide, horizontal support centres for DURAFLO ABS pipe at various temperature is given in the adjacent table. For vertical pipes, support centres may be increased by 50%. For more details contact Viadux.

Pipes operating at higher temperatures, up to 60°C, must be continuously supported.

SUPPORT CENTRES (METRES) BASED ON PN 15 PIPE

Pipe Size DN	Average pipe wall temperature	
	20° C	40° C
15	0.80	0.60
20	0.90	0.70
25	1.00	0.75
32	1.20	0.90
40	1.30	0.95
50	1.50	1.10
65	1.80	1.35
80	2.00	1.50
100	2.30	1.70
125	2.60	1.90
150	3.00	2.20
200	3.50	2.60
225	4.00	2.95
300	4.20	3.10
350	4.50	3.35
375	4.80	3.55
400	5.00	3.70
450	5.50	4.10
500	6.00	4.45
575	6.20	4.60
650	6.40	4.75
750	6.60	4.90

The following correction factors should be applied for other pipe classes.

Pressure Rating	Correction Factors
PN 6	0.71
PN 9	0.88
PN 12	0.92
PN 15	1
PN 18	1.05
PN 20	1.07

DEFLECTING PIPES ON A CURVE

The flexibility of ABS pipes can often be used to an advantage when installing pipe work where a curve is required. The following table gives minimum bending radii without undue stress being placed on a pipe.

Pipes should be curved evenly in the trench. Do not bend pipe around a point. Do not use pegs or stakes to define the radius or the designed curve. Bending aids if required must be padded to prevent damage to pipe. Ensure all solvent weld joints are fully cured before attempting bending of pipe.

It is possible for pipes to be curved to a lesser radius than in the table below depending on the design pressure/temperature relationship. Contact Viadux for further information.

ABS PIPE MINIMUM BEND RADIUS. m

DN	Radius
Up to 65	19.5
80	24
100	30
125	37.5
150	45
175	52
200	60

Bending forces for pipe DN 200 and larger will be excessive and is not recommended.

ABS PIPE & FITTINGS DESIGN MANUAL

COLLAPSE RESISTANCE

DURAFLO ABS pipelines are particularly suitable for below atmospheric applications. For buried pipelines, design for buckling should be based upon AS 2566 Buried flexible pipelines - Design. Critical collapse pressure (differential pressure) for above ground pipelines may be calculated using the following formula:

$$P_{cr} = \frac{2 \times E}{1 - \nu^2} \times \left(\frac{t}{D-t} \right)^3$$

where:

- E = Modulus. MPa
(1580 MPa @ 20°C)
- D = Outside diameter of the pipe. mm
- t = pipe wall thickness. mm
- n = Poisson's ratio, dimensionless
- n = 0.35 for ABS

Note: For temperatures above 20°C Modulus must be derated accordingly.

PRESSURE TESTING

The recommended test pressure for DURAFLO ABS pipe used in above ground systems is 1.5 times the designed operating pressure of the system for a maximum of one hour, less allowance for temperature derating.

Pressure testing above these limits is not recommended as it can reduce the maximum life of the system.

Pressure testing of DURAFLO ABS buried pipelines shall be in accordance with AS 2566 Buried flexible pipelines.

UNSUPPORTED CRITICAL COLLAPSE PRESSURE. MPa

		Initial	Long Term
Pipe outside diameter mm	OD =	60.3	
PN, bar	PN =	9	
Design Hoop Stress MPa	S =	10	
Poisson's ration	n =	0.35	
Ring bending stiffness MPa	Eb =	2200	1580
UNSUPPORTED CRITICAL COLLAPSE PRESSURE. MPa	Pcr =	0.45692	0.32815

PN (ABS 160)	UNSUPPORTED CRITICAL COLLAPSE PRESSURE. MPa	
	Initial	Long Term
4.5	0.057	0.041
6	0.135	0.097
9	0.457	0.328
12	1.083	0.778
15	2.115	1.519
18	3.655	2.625
20	5.014	3.601





INDUSTRIAL PIPE SYSTEMS

ADELAIDE

P: 08 8340 3411
F: 08 8340 3422
E: ccasales@viadux.com.au

MELBOURNE

P: 03 9309 9133
F: 03 9309 6237
E: ccmsales@viadux.com.au

BRISBANE

P: 07 5589 4400
F: 07 5534 7079
E: ccbsales@viadux.com.au

PERTH

P: 08 9346 8500
F: 08 9346 8501
E: ccpsales@viadux.com.au

DARWIN

P: 08 8935 3300
F: 08 8947 3981
E: ccdsales@viadux.com.au

SYDNEY

P: 02 9794 3440
F: 02 9794 3499
E: ccssales@viadux.com.au

GOLD COAST

P: 07 5589 4400
F: 07 5534 7079
E: ccgsales@viadux.com.au

TOWNSVILLE

P: 07 4725 5940
F: 07 4725 4995
E: cctsales@viadux.com.au

VIADUX PTY LTD PO BOX 141 FAIRFIELD, NEW SOUTH WALES 1860 AUSTRALIA / VIADUX.COM.AU / PHONE 1300VIADUX

All Viadux trademarks and logos are owned by Viadux Pty, Ltd. All other brand or product names are trademarks or registered marks of their respective owners. Because we are continuously improving our products and services, Viadux reserves the right to change specifications without prior notice.