



# VARI-GIB® COUPLINGS

DN 40 - DN 1200

NON-RESTRAINED MECHANICAL COUPLINGS FOR CONNECTING PIPES WITH EQUAL OR UNEQUAL DIAMETERS



## FEATURES

Vari-Gib Couplings can be installed without the need to disassemble, significantly improving speed and ease of installation

The variable OD range of each coupling often enables application on more than one pipe type and size, thereby significantly reducing stockholding requirements

Compatible with most pipe types

Specially designed wedge shaped nitrile rubber gaskets are suitable for use with water, wastewater and gas mediums

Fasteners have a captive head configuration to enable single spanner operation, facilitating ease of field assembly

Fasteners are 316 stainless steel for long life operation. Galvanised mild steel is available in sizes up to DN 300

A three bolt design is used in sizes up to DN 150 for ease of installation

Components are pre-lubricated during assembly to assist installation

An extended range of stepped couplings are now available

Manufacturing facility certified to the ISO 9001 quality assured standard

## DESCRIPTION

Vari-Gib non-restrained mechanical couplings provide an effective method for connecting pipes with equal or unequal diameters

## APPLICATION

Vari-Gib Couplings are ideal for joining two pipe ends together and are predominantly used in a maintenance situation where a section of burst or damaged pipeline is repaired by a cut-out and replacement method

Suitable for potable water, wastewater and gas applications. If used on gas piping, prior approval needs to be obtained from the asset manager for its application

Note: Vari-Gib Couplings are not recommended for use on polyethylene pipe.

## TECHNICAL DATA

**Size Range:** DN 40 - DN 1200

Please contact Viadux for information on additional sizes not detailed in this brochure (most sizes to DN 1200 available)

**Maximum Operating Pressure:** 1600 kPa (up to and including DN 600).

**Temperature Range:** -10°C to 60°C

**Product Certification:** AS/NZS 4998 Lic. No. SMKP25236 – applicable up to DN 600

# VARI-GIB COUPLINGS - PN 16 OPERATING PRESSURE

SELECTION CHART: THE WANG COUPLING RANGE EXTENDS BEYOND DN 600. FOR SIZES NOT LISTED BELOW OR FOR FLANGED AND

Nom. Size DN	DICL	STEEL		CICL		AC		ABS*1 Series 1
	AS/NZS 2280	MSCL AS 1579	GW1 AS 1074	B AS 1724	C AS 2544	AB AS 1711	CD AS 1711	AS 3518
40			KV0047DA? 48mm					KV0047DA? 48mm
50			KV0059DA? 60mm			KV0059DA? 69mm		KV0059DA? 60mm
65			KV0072DA? 76mm			KV0072DA? 79mm		KV0072DA? 75mm
80	KV0088D?? 96mm		KV0088D?? 89mm		KV0088D?? 96mm	KV0088D?? 96mm	KV0088D?? 96mm	KV0088D?? 89mm
100	KV0109A?? 122mm	KV0109A?? 114mm	KV0109A?? 114mm	KV0109A?? 122mm	KV0109A?? 122mm	KV0109A?? 122mm	KV0109A?? 122mm	KV0109A?? 114mm
125		KV0123DA? 140mm	KV0123DA? 140mm					KV0123DA? 140mm
150	KV0158A?? KV0170DA? 177mm	KV0158A?? 168mm	KV0158A?? 168mm	KV0158A?? KV0170DA? 177mm	KV0158A?? KV0170DA? 177mm	KV0158A?? KV0170DA? 177mm	KV0158A?? KV0170DA? 177mm	KV0158A?? 168mm
175								
200	KV0214A?? 232mm	KV0214A?? 218mm	Select missing End Code from Material Options table. Also see Typical specifying sequence	KV0214A?? 232mm	KV0214A?? 232mm	KV0214A?? 232mm	KV0214A?? 232mm	KV0214A?? 225mm
225	KV0240A?? 259mm	KV0240A?? 257mm		KV0240A?? 259mm	KV0240A?? 259mm	KV0240A?? 259mm	KV0240A?? 259mm	KV0240A?? 250mm
250	KV0272A?? 286mm	KV0272A?? 273mm		KV0272A?? 286mm	KV0272A?? 286mm	KV0272A?? 286mm	KV0272A?? 286mm	
300	KV0330A?? 345mm	KV0310A?? 324mm		KV0330A?? 334mm	KV0330A?? 345mm	KV0330A?? 334mm	KV0330A?? 345mm	KV0310A?? 315mm
350		KV0346CDS 356mm						KV0346CDS 355mm
375	KV0410CDS 426mm	KV0396CDS 406mm		KV0410CDS 413mm	KV0410CDS 426mm	KV0410CDS 413mm	KV0410CDS 426mm	KV0396CDS 400mm
400		KV0444CDS KV0436CDS 457mm						KV0436CDS 450mm
450	KV0498CDS KV0488CDS 507mm	KV0498CDS KV0488CDS 508mm		KV0488CDS 492mm	KV0498CDS KV0488CDS 507mm	KV0488CDS 492mm	KV0498CDS KV0488CDS 507mm	KV0488CDS 500mm
500	KV0552CDS KV0542CDS 560mm	KV0552CDS KV0542CDS 559mm		KV0530CDS 545mm	KV0542CDS KV0552CDS 560mm			KV0552CDS 560mm
525		KV0596CDS 610mm				KV0560CDS KV0552CDS 572mm	KV0574CDS 587mm	
600	KV0658CDS KV0648CDS 667mm	KV0648CDS KV0658CDS 660mm		KV0648CDS KV0630CDS 650mm	KV0658CDS KV0648CDS 667mm	KV0648CDS KV0630CDS 650mm	KV0658CDS KV0648CDS 667mm	KV0620CDS 630mm

Note: \*1 Min. required pipe rating for coupling application: PN 9 \*2 Min. required pipe rating for coupling application: SN5,000 \*3 Min. required pipe rating

## BLANK END COUPLINGS, PLEASE CONTACT PENTAIR WATER SOLUTIONS

GRP*2 Series 1 – B5	RC	COPPER	PVC-U/M/O*3	
			Series 1 (U) AS/NZS 1477 (M) AS/NZS 4765 (O) AS/NZS 4441	Series 2 (U) AS/NZS 1477 (M) AS/NZS 4765 (O) AS/NZS 4441
AS 3571	AS 4058	AS 1432		
		N/A	KV0047DA?	
		38mm	48mm	
		KV0047DA?	KV0059DA?	
		51mm	60mm	
		KV0059DA?	KV0072DA?	
		64mm	75mm	
		KV0072DA?	KV0088D??	
		76mm	89mm	
KV0109A?? 122mm		KV0088D??	KV0109A??	KV0109A??
		101mm	114mm	122mm
		KV0123DA?	KV0123DA?	
		127mm	140mm	
KV0158A?? KV0170DA?	KV0178DA?	N/A	KV0158A??	KV0158A?? KV0170DA?
177mm	197mm	152mm	160mm	177mm
			KV0178DA??	
			200mm	
KV0214A?? 232mm		N/A	KV0214A??	KV0214A??
		203mm	225mm	232mm
KV0240A?? 259mm	KV0272A??	KV0214A??	KV0240A??	KV0240A??
	279mm	229mm	250mm	259mm
KV0272A?? 286mm			KV0272A??	KV0272A??
			280mm	286mm
KV0330A?? 345mm	KV0346CDS		KV0310A??	KV0330A??
	362mm		315mm	345mm
KV0396CDS 399mm			KV0346CDS	
			355mm	
KV0410CDS 426mm	KV0444CDS		KV0396CDS	KV0410CDS
	445mm		400mm	426mm
KV0444CDS			KV0436CDS	
KV0436CDS 453mm			KV0444CDS	
			450mm	
KV0498CDS KV0488CDS	KV0522CDS		KV0488CDS	KV0498CDS KV0488CDS
507mm	533mm		500mm	507mm
KV0552CDS KV0542CDS			KV0552CDS	
560mm			KV0542CDS	
			560mm	
KV0574CDS	KV0600CDS			KV0552CDS KV0542CDS
587mm	616mm			560mm
KV0658CDS KV0648CDS			KV0620CDS	KV0658CDS KV0648CDS
667mm			630mm	667mm

Recommended Coupling  
Alternative Coupling

Pipe OD

## MATERIAL OPTIONS

DN	BARREL & FLANGES			BARREL LENGTH A = 110 mm B = 136 mm C = 176 mm D = 216 mm		FASTENERS		VARIABLE OPTIONS - END CODE
	DI-FBE COATED	S/STEEL BARREL & DI-FBE FLANGES	STAINLESS STEEL	SHORT - mm	LONG - mm	GALVANISED	STAINLESS STEEL	
40-65	D			A			S	DAS
	D			A		G		DAG
80	D			A			S	DAS
	D			A		G		DAG
	D				C		S	DCS
125 150OS 175	D				C	G		DCG
	D			A			S	DAS
100 150	D			A		G		DAG
		A		A			S	AAS
		A		A		G		AAG
		A			C		S	ACS
200 225		A			C	G		ACG
		A		B			S	ABS
		A		B		G		ABG
250		A			C		S	ACS
		A			C	G		ACG
		A			C	G		ACG
300		A		C			S	ACS
		A			C	G		ACG
		A			D		S	ADS
350 (34600+)			C		D	G		ADG
					D		S	CDS

g for coupling application: U = PN 9 / M = PN 12 / O = PN 16

# VARI-GIB COUPLINGS

## PARTS LIST

No.	Description / Material / Standard
1	Barrel Ductile Iron / AS 1831 316 Stainless Steel / ASTM A240M
2	Flanges Ductile Iron / AS 1831 316 Stainless Steel / ASTM A276
3	Bolts 316 Stainless Steel / DIN 603 Mild Steel – Galvanised / DIN 603
4	Nuts 316 Stainless Steel / AS 1112.1 Mild Steel – Galvanised / DIN 603
5	Washers 316 Stainless Steel / ISO 887/ISO 7089 Mild Steel – Galvanised
6	Gasket Nitrile (NBR) Compound AS 1646 and AS/NZS 4020
7	Coating Fusion Coated / AS/NZS 4158

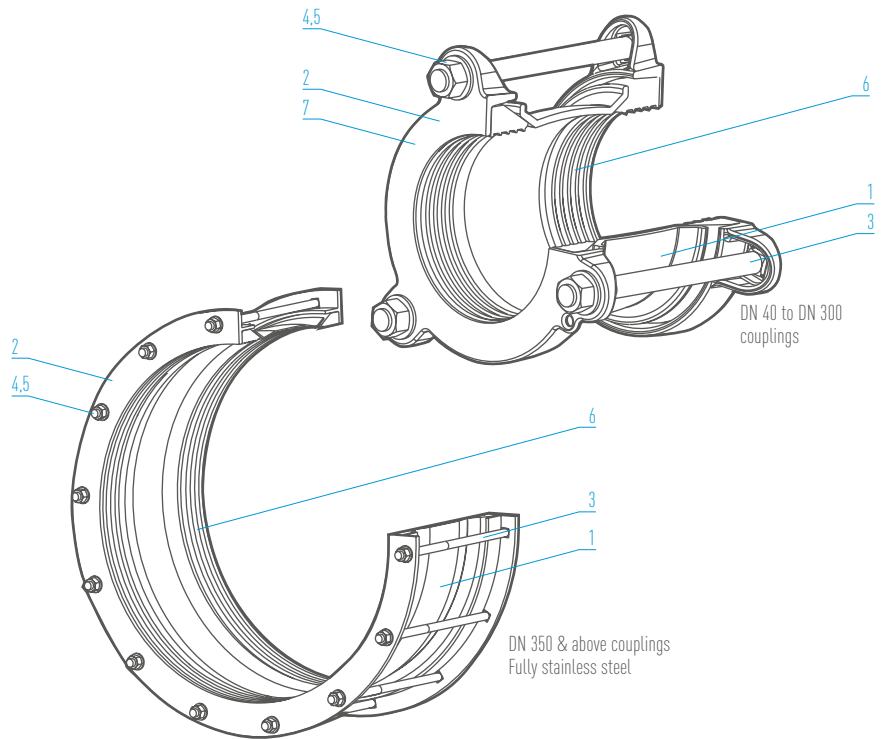

## STRAIGHT COUPLINGS

See pages 6 and 7 for selection options



## STEPPED COUPLINGS

See pages 5 for selection options



# VARI-GIB STEPPED COUPLINGS

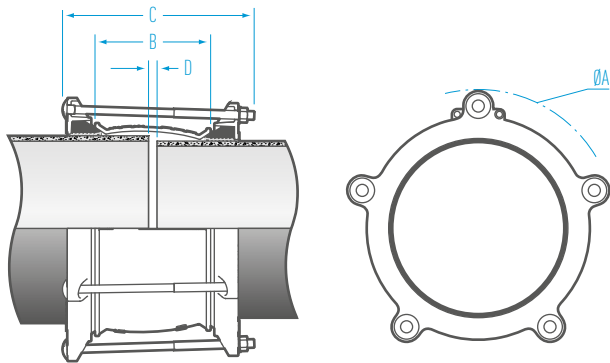

## TYPICAL SPECIFYING SEQUENCE

	KV	S	0088	0109	D	C	S
KV	= Vari-Gib						
S	= Stepped						
0088	= OD indicator Smaller end of the coupling						
0109	= OD indicator Larger end of the coupling						
D	= DI fusion coated barrel and flanges						
C	= Barrel length Select length from the Dimensions Table below C = 176 / D = 214						
S	= Fastener material Select from the Materials Table below G = Galvanised / S = 316 stainless steel						

## DIMENSIONS

Nominal Size DN	Smaller end		Larger end		Bolt		Total angular deflection	Barrel length B	Bolt length C	Max pipe gap D	Min pipe gap D	Approx weight kg
	OD range	Flange OD A	OD range	Flange OD A	Qty	Size						
80 / 100	88-103	238	109-133	263	3	M16	6°	176	300	15	12	7.5
100 / 150	109-133	263	158-182	312	3	M16	6°	216	350	80	15	12
125 / 150	123-147	277	158-182	312	3	M16	6°	216	350	80	15	12.5
200 / 225	214-238	371	240-264	399	5	M16	6°	216	350	80	15	21
225 / 250	240-264	399	272-296	431	6	M16	6°	216	350	80	15	24
300 / 300	310-334	490	330-354	510	6	M16	6°	216	350	80	15	33

300+ Fabricated 316 stainless steel stepped couplings available above DN 300. Price and availability upon request

All dimensions in millimetres unless stated otherwise

## MATERIAL OPTIONS

Nominal Size DN	Barrel Ductile Iron FC blue AS/NZS 4158	Flanges Ductile Iron FC blue AS/NZS 4158	Fasteners		Gasket Nitrile rubber
			316 stainless steel	Galv mild steel	
80 / 100	✓	✓	✓	✓	✓
100 / 150	✓	✓	✓	✓	✓
125 / 150	✓	✓	✓	✓	✓
200 / 225	✓	✓	✓	✓	✓
225 / 250	✓	✓	✓	✓	✓
300 / 300	✓	✓	✓	✓	✓

All dimensions in millimetres

# VARI-GIB STRAIGHT COUPLINGS

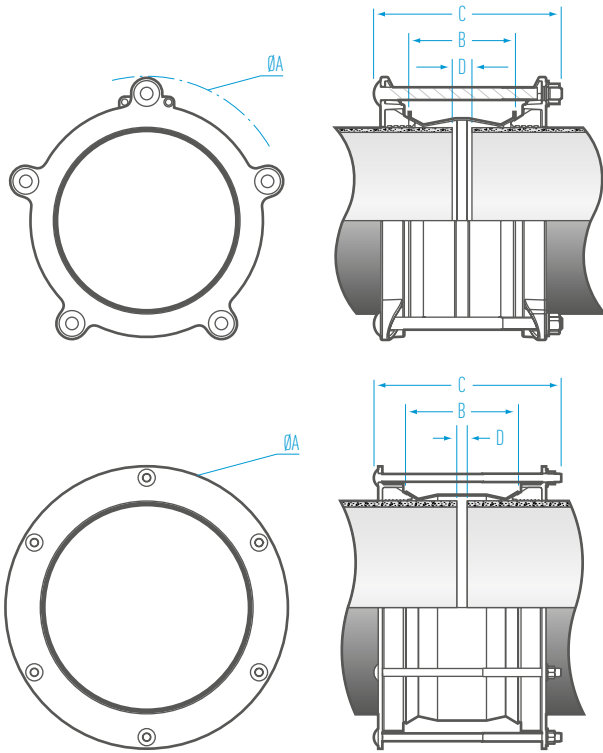

## TYPICAL SPECIFYING SEQUENCE

		KV	0109	A	A	S
KV	= Vari-Gib					
0109	= OD range Select code from Vari-Gib Selection Chart on pages 2 and 3					
A	= Material options Select from Material Options Table in the Selection Chart A = 316 S/S Barrel with D I-Fusion Coated Flanges C = 316 S/S Barrel and Flanges D = DI Fusion Coated Barrel and Flanges					
A	= Barrel length Select length from Dimensions Table below A = 110 / B = 136 / C = 176 / D = 216					
S	= Fastener material Select from Material Options Table opposite G = Galvanised / S = 316 stainless steel					

## DIMENSIONS

OD range		Flange OD A	Bolt		Total angular deflection	Barrel length B		Bolt length C		Max. pipe gap D		Min. pipe gap D		Approx. weight kg
Start	End		Qty	Size		Short	Long	Short	Long	Short	Long	Short	Long	
47	59	191	3	M12	6°	110		200		15		12		4
59	71	198	3	M12	6°	110		200		15		12		4.5
72	84	213	3	M12	6°	110		200		15		12		5
88	103	238	3	M16	6°	110	176	240	300	15	50	12	12	5.5
109	133	263	3	M16	6°	110	176	240	300	15	50	12	12	6.5
123	147	277	3	M16	6°	110		240		15		12		8
158	182	312	3	M16	6°	110	176	240	300	15	50	12	12	7.5
170	194	324	3	M16	6°	110		240		15		12		8.5
178	202	332	4	M16	6°	110		240		15		12		10
214	238	371	5	M16	6°	136	176	240	300	30	50	15	15	11
240	264	399	5	M16	6°	136	176	240	300	30	50	15	15	13
272	296	431	6	M16	6°	136	176	240	300		50		15	14
310	334	490	6	M16	6°	176	216	300	350		80		15	24
330	354	510	6	M16	6°	176	216	300	350		80		15	26
346	370	504	8	M16	6°		216		350		80		15	30
396	420	554	8	M16	5°		216		350		80		15	37
410	434	568	8	M16	5°		216		350		80		15	38
436	460	594	8	M16	4°		216		350		80		15	42
444	468	602	8	M16	4°		216		350		80		15	45
488	512	646	10	M16	4°		216		350		80		15	49.5
498	522	656	10	M16	4°		216		350		80		15	51
522	546	679	12	M16	4°		216		350		80		15	56
530	554	688	12	M16	4°		216		350		80		15	57
542	566	700	12	M16	4°		216		350		80		25	58
552	576	710	12	M16	4°		216		350		80		25	59
560	584	717	12	M16	4°		216		350		80		25	60
574	598	732	12	M16	4°		216		350		80		25	61
596	620	754	14	M16	4°		216		350		80		25	65
620	644	777	14	M16	3°		216		350		80		25	69
630	654	788	14	M16	3°		216		350		80		25	70
648	672	806	14	M16	3°		216		350		80		25	71.5
658	682	816	14	M16	3°		216		350		80		25	72

All dimensions in millimetres unless stated otherwise

# VARI-GIB STRAIGHT COUPLINGS

## MATERIAL OPTIONS

OD Range		Barrel		Flanges		Fasteners		Gasket
Start	End	Ductile Iron FC blue AS/NZS 4158	316 Stainless Steel	Ductile Iron FC Blue AS/NZS 4158	316 Stainless Steel	316 Stainless steel	Galv Mild Steel	Nitrile Rubber
47	59	✓		✓		✓	✓	✓
59	71	✓		✓		✓	✓	✓
72	84	✓		✓		✓	✓	✓
88	103	✓		✓		✓	✓	✓
109	133		✓	✓		✓	✓	✓
123	147	✓		✓		✓	✓	✓
158	182		✓	✓		✓	✓	✓
170	194	✓		✓		✓	✓	✓
178	202	✓		✓		✓	✓	✓
214	238		✓	✓		✓	✓	✓
240	264		✓	✓		✓	✓	✓
272	296		✓	✓		✓	✓	✓
310	334		✓	✓		✓	✓	✓
330	354		✓	✓		✓	✓	✓
346	370		✓		✓	✓		✓
396	420		✓		✓	✓		✓
410	434		✓		✓	✓		✓
436	460		✓		✓	✓		✓
444	468		✓		✓	✓		✓
488	512		✓		✓	✓		✓
498	522		✓		✓	✓		✓
522	546		✓		✓	✓		✓
530	554		✓		✓	✓		✓
542	566		✓		✓	✓		✓
552	576		✓		✓	✓		✓
560	584		✓		✓	✓		✓
574	598		✓		✓	✓		✓
596	620		✓		✓	✓		✓
620	644		✓		✓	✓		✓
630	654		✓		✓	✓		✓
648	672		✓		✓	✓		✓
658	682		✓		✓	✓		✓

# WANG CLAMPS & COUPLINGS

WANG is one of the leading manufacturers and suppliers of Grade 316 Stainless Steel Repair and Tapped Clamps as well as Couplings for reticulated water, sewerage and gas mains including industrial piping systems.

WANG products have become synonymous with quality and reliability. Our product range is widely utilised and relied upon by Water Authorities and Councils throughout Australia in the installation and maintenance of their supply mains and reticulation network.



WANG products can be sourced through the Viadux national sales and service network of customer centres.

Viadux is a specialist in integrated solutions for all your water and wastewater pipeline system requirements.

## KWIK CLAMPS

A full circle repair clamp for small bore galvanised steel, copper and PVC pipe. DN 15 - DN 50

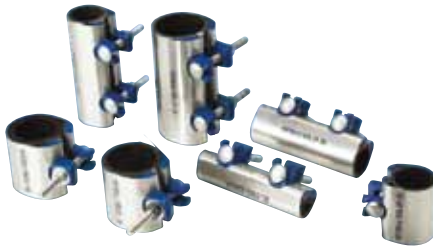

## REPAIR CLAMPS

A fast, permanent and economical repair solution for most pipe types and sizes. DN 50 - DN 1200



## TAPPED CLAMPS

A reliable means of tapping into old, unstable or damaged pipe. DN 50 - DN 1200



## TAPPING SADDLES

Permanent tapping solution for both rigid and flexible pipe. DN 40 - DN 450



## FLANGED OFFTAKE CLAMPS

A cost effective means of achieving a "T" connection or under pressure tapping. DN 100 - DN 900



## SEWER OB JUNCTION CLAMPS

A quick method of installing a new property service connection on a sewer main. DN 100 - DN 450



## VARI-FLANGED COUPLINGS

Enable connection between a stub ended pipe and a mating flanged face. DN 80 - DN 600



## HIGH PRESSURE COUPLINGS

Provides a mechanical joint between similar or dissimilar pipes in high pressure environments. DN 150 - DN 2000



## SOCKET JOINT LEAK CLAMPS

Provide a permanent and economical seal over a leaking socket-spigot joint. DN 80 - DN 1200

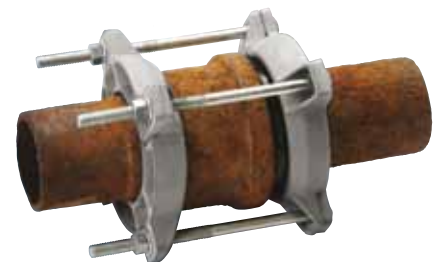

### DISTRIBUTED BY VIADUX

**ADELAIDE**  
P: 08 8340 3411  
F: 08 8340 3422  
E: ccasales@viadux.com.au

**BRISBANE**  
P: 07 5589 4400  
F: 07 5534 7079  
E: ccbsales@viadux.com.au

**DARWIN**  
P: 08 8935 3300  
F: 08 8947 3981  
E: ccdsales@viadux.com.au

**GOLD COAST**  
P: 07 5589 4400  
F: 07 5534 7079  
E: ccgsales@viadux.com.au

**MELBOURNE**  
P: 03 9309 9133  
F: 03 9309 6237  
E: ccmsales@viadux.com.au

**PERTH**  
P: 08 9346 8500  
F: 08 9346 8501  
E: ccpsales@viadux.com.au

**SYDNEY**  
P: 02 9794 3440  
F: 02 9794 3499  
E: ccssales@viadux.com.au

**TOWNSVILLE**  
P: 07 4725 5940  
F: 07 4725 4995  
E: cctsales@viadux.com.au

### WANG COMPONENTS

CNR GIBSON STREET & SANDFORD ROAD, WANGARATTA, VICTORIA 3677  
PHONE 03 5722 7400 / FAX 03 5722 7444

All WANG trademarks and logos are owned by Wang Components. All other brand or product names are trademarks or registered marks of their respective owners. Because we are continuously improving our products and services, Wang Components reserves the right to change specifications without prior notice. AP0315 © 2015 Wang Components. All Rights Reserved.

