



# POLY-GIB COUPLINGS

## DN 90 - DN 180

RESTRAINED MECHANICAL COUPLING FOR CONNECTING TO HDPE PIPE



### FEATURES

The Poly-Gib range comes in a variety of configuration. Straight couplings, stepped couplings, flange adaptors and blank ends

The Poly-Gib range of restrained couplings can be installed without the need to disassemble, significantly improving speed and ease of installation

No internal stiffener require in application on HDPE pipe of SDR 11 or less

Nitrile rubber seals suitable for potable water, waste water and oil/gas applications

Fasteners feature a captive head configuration enabling single spanner installation

Stainless steel components made from 316SS, that has been fully pickled and passivated

Three bolt design is used in sizes up to DN 180 to improve installation in the field

Components are pre-lubricated during assembly to assist installation

Tapping pads on the blank end products permit a drain, flush or sampling point to be added to the system

Manufacturing facility certified to ISO 9001 Quality Assured Standard

### DESCRIPTION

Poly-Gib Mechanically Restrained Couplings, Flange Adaptors and Blank Ends provide an effective method for connecting HDPE pipe to new and existing pipe infrastructure

The Poly-Gib range utilises a mechanical restraint and sealing system that is not effected by the presence of water, dirt or other contaminates, making it ideal as a universal coupling system

The Poly-Gib straight and stepped couplings are ideal for connecting two HDPE pipes as either part of a new installation or as part of a pipe repair

### APPLICATION

Poly-Gib Flange Adaptors are ideal for connecting HDPE pipe to flanged fittings or valves and are particularly useful in installing new valves into existing pipelines

Poly-Gib Blank Ends provide an effective end cap that does not require thrust blocks to secure. The ability to complete an onsite tapping in the side and end of the cap is very useful in providing domestic connections, pressure testing new line or water sampling

Poly-Gib Couplings are suitable for potable water, raw water, waste water and oil/gas applications. If used on gas applications, approval must be obtained from the asset manager before installation

### TECHNICAL DATA

**Size Range:** DN 90 - DN 180

**Maximum Operating Pressure:** 1600 kPa

**Temperature Range:** -10°C to 60°C

**Relevant Standards:**

AS/NZS 4129:2000 - Fittings for polyethylene (PE) pipes for pressure applications

StandardsMark Licence  
Certificate No SMK40080

Not applicable to Stepped Couplings

# STRAIGHT POLY-GIB COUPLINGS



## DIMENSIONS

Nom. size DN	Product code	Flange OD A	Bolt detail		Barrel length B	Bolt length C	Pipe gap		Barrel material	Weight APPROX. kg
			Qty	Size			D Minimum	D Maximum		
90	KR0090DCS	238	3	M16	176	300	15	50	DI	7.4
110	KR0110ACS	265	3	M16	176	300	15	50	SS	8.4
125	KR0125ACS	265	3	M16	176	300	15	50	SS	8.7
160	KR0160ACS	315	3	M16	176	300	15	50	SS	10.4
180	KR0180ACS	315	3	M16	176	300	15	50	SS	10.3

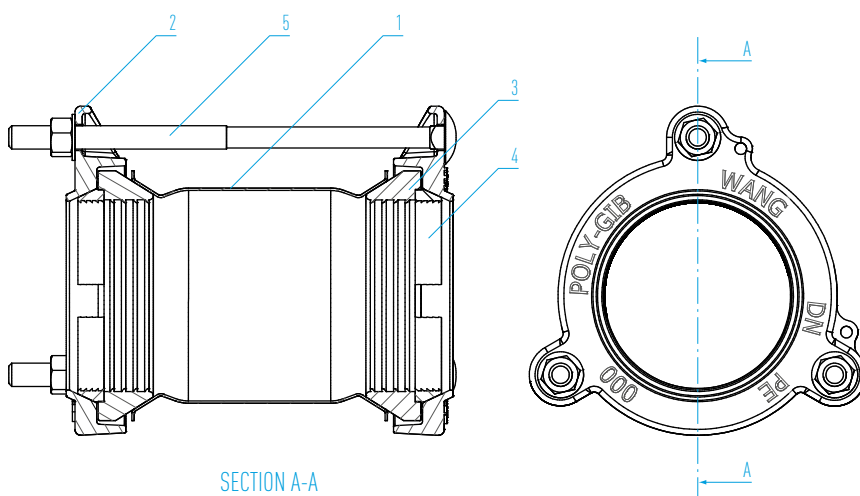

## PARTS LIST

No.	Description	Material / Standard
1	Barrel	Ductile iron / AS 1831 316 stainless steel / ASTM A240M
2	Flanges	Ductile iron AS 1831
3	Gaskets	Nitrile (NBR) compound AS 1646 and AS 4020
4	Grippers	Copper alloy AS 2345 and BS 1400
5	Bolts	316 stainless steel DIN 603
6	Washers	316 stainless steel ISO 887 and ISO 7089
7	Nuts	316 stainless steel AS 1112.1
8	Coating	Fusion bonded epoxy ON DUCTILE IRON PARTS AS/NZS 4158

# STEPPED POLY-GIB COUPLINGS



## DIMENSIONS

Nom. size DN	Product code	Flange OD		Bolt detail		Barrel length B	Bolt length C	Pipe gap		Barrel material	Weight APPROX. kg
		A Small	A Large	Quantity	Size			D Minimum	D Maximum		
90 / 110	KRS00900110DCS	238	265	3	M16	176	300	15	50	DI	9.4
90 / 125	KRS00900125DCS	238	265	3	M16	176	300	15	50	DI	9.5
110 / 125	KRS01100125ACS	265	265	3	M16	176	300	15	50	SS	8.5
110 / 160	KRS01100160ACS	265	315	3	M16	216	350	15	50	DI	13.1
110 / 180	KRS01100180ACS	265	315	3	M16	216	350	15	50	DI	13.1
125 / 160	KRS01250160ACS	265	315	3	M16	216	350	15	50	DI	13.3
125 / 180	KRS01250180ACS	265	315	3	M16	216	350	15	50	DI	13.2
160 / 180	KRS01600180ACS	315	315	3	M16	176	300	15	50	SS	10.4

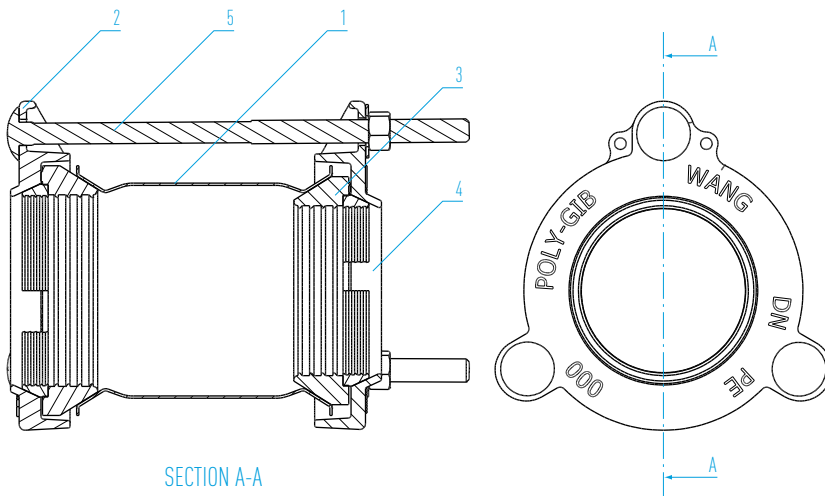

## PARTS LIST

No.	Description	Material / Standard
1	Barrel	Ductile Iron / AS 1831 316 Stainless Steel / ASTM A240M
2	Flanges	Ductile Iron AS 1831
3	Gaskets	Nitrile (NBR) Compound AS 1646 and AS 4020
4	Grippers	Copper Alloy AS 2345 and BS 1400
5	Bolts	316 Stainless Steel DIN 603
6	Washers	316 Stainless Steel ISO 887 and ISO 7089
7	Nuts	316 Stainless Steel AS 1112.1
8	Coating	Fusion Bonded Epoxy ON DUCTILE IRON PARTS AS/NZS 4158

# POLY-GIB FLANGE ADAPTER



## DIMENSIONS

Nom. size DN	Product code	Flange OD A	Bolt detail		Barrel length B	Bolt length C		Pipe gap		Barrel material	Weight APPROX. kg
			Qty	Size		D Minimum	D Maximum				
110	KRFA0110F100DCS	265	3	M16	150	200	15	50	DI	10.4	
125	KRFA0125F100DCS	265	3	M16	150	200	15	50	DI	10.5	
160	KRFA0160F150DCS	315	3	M16	150	200	15	50	DI	13.9	
180	KRFA0180F150DCS	315	3	M16	150	200	15	50	DI	13.8	

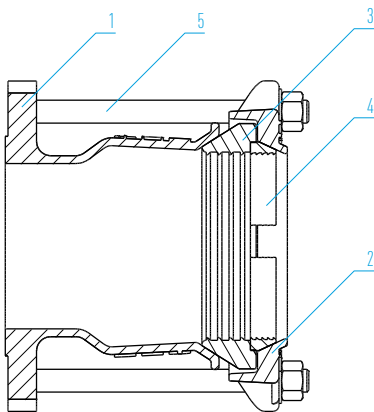

SECTION A-A

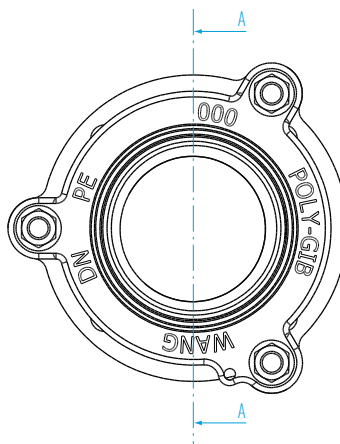

## PARTS LIST

No.	Description	Material / Standard
1	Body	Ductile iron BARREL & FLANGE AS 1831
2	Coupling flange	Ductile iron AS 1831
3	Gasket	Nitrile (NBR) compound AS 1646 and AS 4020
4	Gripper	Copper alloy AS 2345 and BS 1400
5	Bolts	316 stainless steel DIN 603
6	Washers	316 stainless steel ISO 887 and ISO 7089
7	Nuts	316 stainless steel AS 1112.1
8	Coating	Fusion bonded epoxy ON DUCTILE IRON PARTS AS/NZS 4158

# POLY-GIB BLANK END



## DIMENSIONS

Nom. size DN	Product code	Flange OD A	Bolt detail		Barrel length B	Bolt length C	Pipe gap		Barrel material	Weight APPROX. kg
			Quantity	Size			D Minimum	D Maximum		
90	KRB0090DCS	238	3	M16	107	125	15	50	DI	6.3
110	KRB0110DCS	265	3	M16	107	125	15	50	DI	9.4
125	KRB0125DCS	265	3	M16	107	125	15	50	DI	9.5
160	KRB0160DCS	315	3	M16	107	125	15	50	DI	12.5
180	KRB0180DCS	315	3	M16	107	125	15	50	DI	12.4

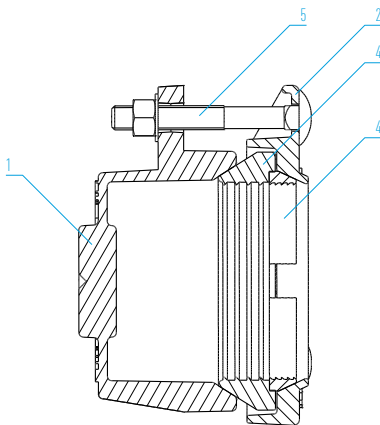

SECTION A-A

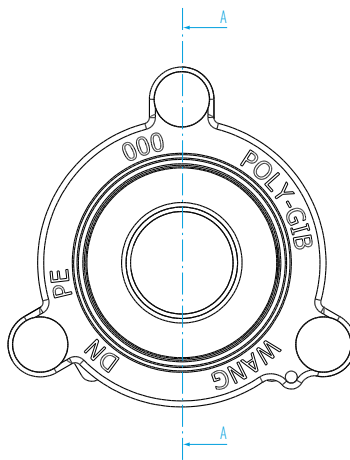

## PARTS LIST

No.	Description	Material / Standard
1	Barrel	Ductile iron / AS 1831 316 stainless steel / ASTM A240M
2	Flanges	Ductile iron AS 1831
3	Gaskets	Nitrile (NBR) compound AS 1646 and AS 4020
4	Grippers	Copper alloy AS 2345 and BS 1400
5	Bolts	316 stainless steel DIN 603
6	Washers	316 stainless steel ISO 887 and ISO 7089
7	Nuts	316 stainless steel AS 1112.1
8	Coating	Fusion bonded epoxy ON DUCTILE IRON PARTS AS/NZS 4158



# CLAMPS & COUPLINGS

WANG is one of the leading manufacturers and suppliers of Grade 316 Stainless Steel Repair and Tapped Clamps as well as Couplings for reticulated water, sewerage and gas mains including industrial piping systems.

WANG products have become synonymous with quality and reliability. Our product range is widely utilised and relied upon by Water Authorities and Councils throughout Australia in the installation and maintenance of their supply mains and reticulation network.



WANG products can be sourced through the Viadux national sales and service network of customer centres.

Viadux is a specialist in integrated solutions for all your water and wastewater pipeline system requirements.

## KWIK CLAMPS

A full circle repair clamp for small bore galvanised steel, copper and PVC pipe. DN 15 - DN 50

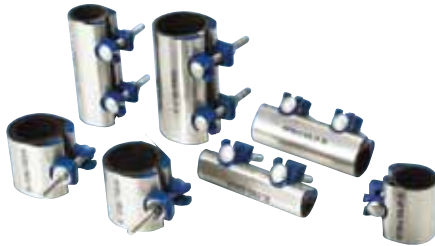

## HDPE CLAMPS

A range of Flanged, Tapped and Repair Clamps specifically for HDPE pipe installations. DN 40 - DN 600



## TAPPED CLAMPS

A reliable means of tapping into old, unstable or damaged pipe. DN 50 - DN 1200



## TAPPING SADDLES

Permanent tapping solution for both rigid and flexible pipe. DN 40 - DN 450

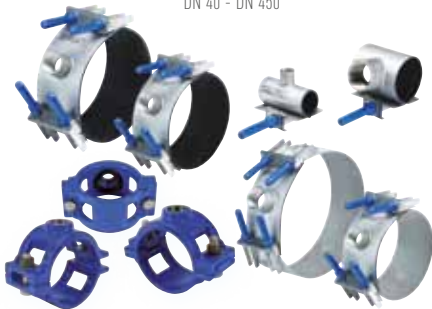

## FLANGED OFFTAKE CLAMPS

A cost effective means of achieving a 'T' connection or under pressure tapping. DN 100 - DN 900



## SEWER OB JUNCTION CLAMPS

A quick method of installing a new property service connection on a sewer main. DN 100 - DN 450



## VARI GIB COUPLINGS

Non-restrained mechanical couplings for connecting pipes with equal or unequal diameters. DN 40 - DN 1200



## HIGH PRESSURE COUPLINGS

Provides a mechanical joint between similar or dissimilar pipes in high pressure environments. DN 150 - DN 2000



## SOCKET JOINT LEAK CLAMPS

Provide a permanent and economical seal over a leaking socket-spigot joint. DN 80 - DN 1200



### DISTRIBUTED BY VIADUX

**ADELAIDE**  
P: 08 8340 3411  
F: 08 8340 3422  
E: ccasales@viadux.com.au

**BRISBANE**  
P: 07 5589 4400  
F: 07 5534 7079  
E: ccbsales@viadux.com.au

**DARWIN**  
P: 08 8935 3300  
F: 08 8947 3981  
E: ccdsales@viadux.com.au

**GOLD COAST**  
P: 07 5589 4400  
F: 07 5534 7079  
E: ccgsales@viadux.com.au

**MELBOURNE**  
P: 03 9309 9133  
F: 03 9309 6237  
E: ccmsales@viadux.com.au

**PERTH**  
P: 08 9346 8500  
F: 08 9346 8501  
E: ccpsales@viadux.com.au

**SYDNEY**  
P: 02 9794 3440  
F: 02 9794 3499  
E: ccssales@viadux.com.au

**TOWNSVILLE**  
P: 07 4725 5940  
F: 07 4725 4995  
E: cctsales@viadux.com.au

### WANG COMPONENTS

CNR GIBSON STREET & SANDFORD ROAD, WANGARATTA, VICTORIA 3677  
PHONE 03 5722 7400 / FAX 03 5722 7444

All WANG trademarks and logos are owned by Wang Components. All other brand or product names are trademarks or registered marks of their respective owners. Because we are continuously improving our products and services, Wang Components reserves the right to change specifications without prior notice. AP0315 © 2015 Wang Components. All Rights Reserved.

