

SUREFLOW® FLANGED FITTINGS DUCTILE IRON PIPELINE SYSTEMS

DN 80 - DN 750. MANUFACTURED TO AS/NZS 2280. FLANGE DIMENSIONS TO AS 4087



Ductile Iron fittings provide high strength and impact resistance

Suitable for 'in ground' or 'above ground' applications

All fittings are supplied with a thermally bonded polymeric coating for long life corrosion protection

Cement lined/bitumen coated fittings available upon request to suit local utility requirements

Self anchoring joints. No need for external anchorages

Integrally cast flanges on fittings

All flange dimensions comply with AS 4087

Alternate flange dimensions available on request.

DESCRIPTION

SUREFLOW® high strength Ductile Iron Flanged Fittings are available in a comprehensive range of sizes and configurations for pipeline construction in both above and below ground applications

GENERAL APPLICATION

SUREFLOW® Flanged Fittings provide restrained non-flexible joints in pipelines or within pipework arrangements and are commonly used in above ground applications such as pump stations and treatment plants

TECHNICAL DATA

Size Range

DN 80 - DN 750

Allowable Operating Pressure

1600 or 3500kPa

Certifications

ISO 9001:2008. QAC/R61/0412

ISC AS/NZS 2280 Certified Product

Licence No. PRD/R61/0412

AS/NZS 4020 Testing of products

for use in contact with drinking water



SUREFLOW® FLANGED FITTINGS

DUCTILE IRON PIPELINE SYSTEMS

FLANGED BENDS

Nom size DN	r	Dimensions, b			
		90°	45°	22½°	11¼°
80	140	229	140	140	125
100	152	241	152	152	152
150	190	279	190	190	190
200	203	305	203	203	203
225	229	330	229	229	229
250	254	356	254	254	254
300	305	406	305	305	305
375	381	495	381	381	381
450	457	572	457	457	457
500	508	622	508	508	508
600	610	737	610	610	610
750	765	905	460	295	230

AUSLITE® fittings are highlighted in salmon

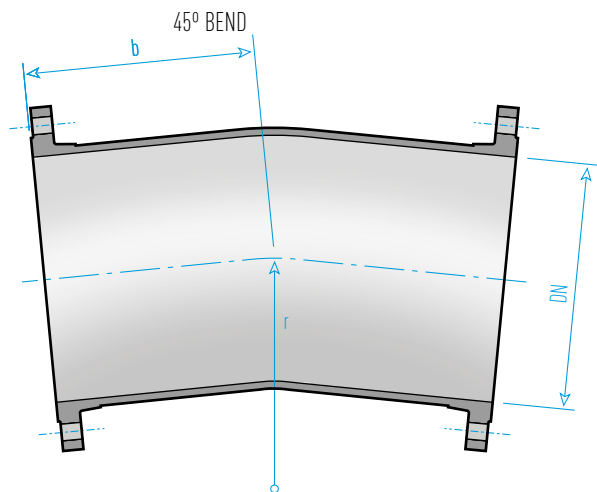
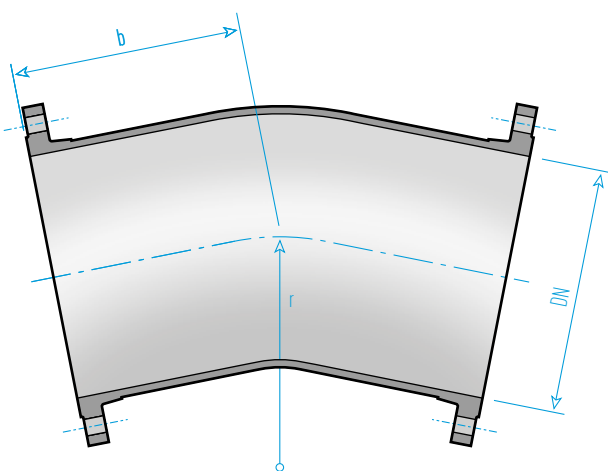
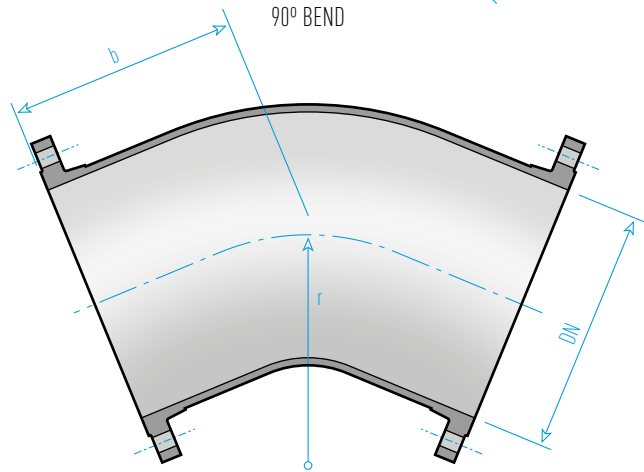
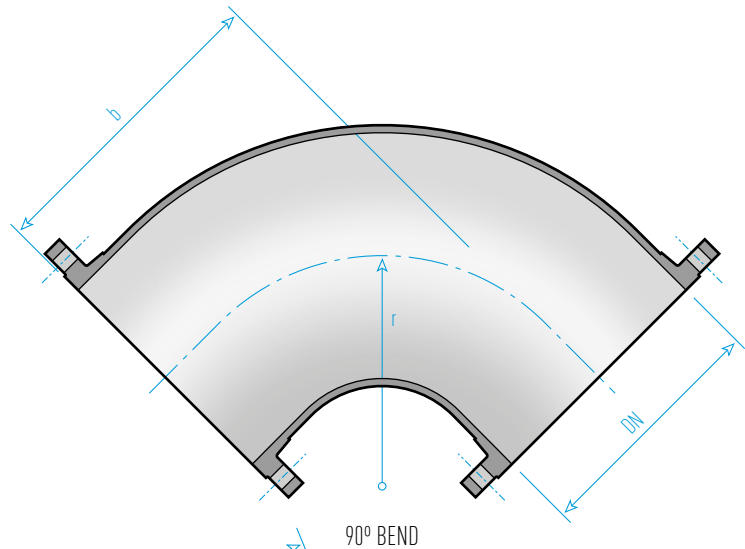

22½° BEND

SYMBOL



11¼° BEND

SUREFLOW® FLANGED FITTINGS DUCTILE IRON PIPELINE SYSTEMS

FLANGED TEES

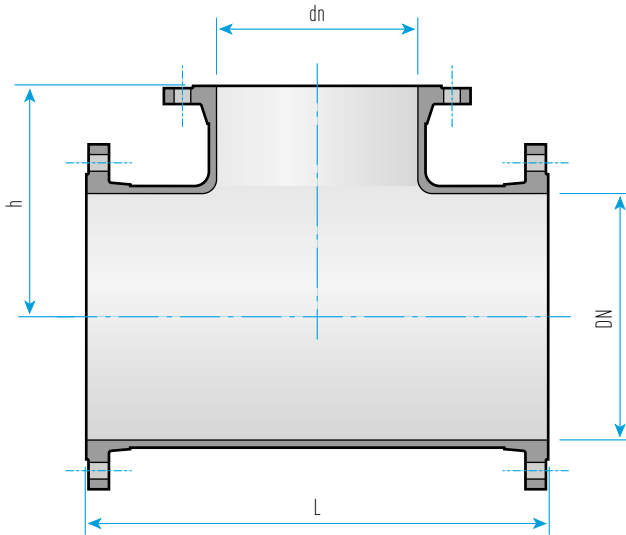

SYMBOL



Nom size		Dimensions	
Body DN	Branch dn	h	L
375	200	356	738
375	225	356	738
375	250	356	738
375	300	356	738
375	375	368	738
450	250	394	814
450	300	394	814
450	375	406	814
450	450	406	814
500	250	432	890
500	300	432	890
500	375	444	890
500	450	444	890
500	500	444	890
600	300	483	1016
600	375	495	1016
600	450	495	1016
600	500	495	1016
600	600	508	1016
750	300	615	890
750	375	645	1000
750	450	655	1080
750	500	680	1160
750	600	695	1260
750	750	725	1450

Nom size		Dimensions	
Body DN	Branch dn	h	L
80	80	137	353
100	80	178	356
100	100	178	356
150	100	203	406
150	150	203	406
200	100	241	484
200	150	241	484
200	200	241	484
225	100	254	508
225	150	254	508
225	200	254	508
225	225	254	508

Nom size		Dimensions	
Body DN	Branch dn	h	L
250	150	267	534
250	200	267	534
250	225	267	534
250	250	267	534
300	100	305	610
300	150	305	610
300	200	305	610
300	225	305	610
300	250	305	610
300	300	305	610

AUSLITE® fittings are highlighted in salmon

SUREFLOW® FLANGED FITTINGS

DUCTILE IRON PIPELINE SYSTEMS

FLANGED TAPERS

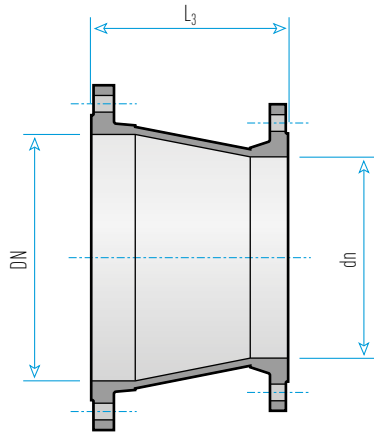

CONCENTRIC

SYMBOL

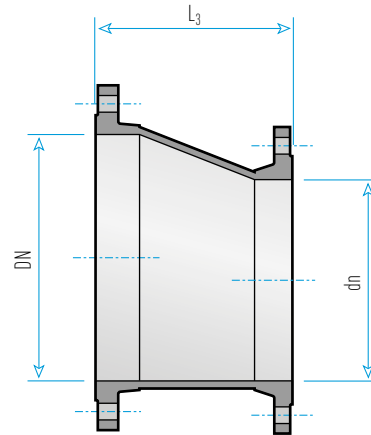

ECCENTRIC

SYMBOL



Nominal Size		
DN	dn	L ₃
100	80	165
150	80	298
150	100	235
200	100	368
200	150	248
225	100	432
225	150	311
225	200	190
250	100	495
250	150	375
250	200	254
250	225	190

AUSLITE® fittings are highlighted in salmon - concentric tapers only

Nominal Size		
DN	dn	L ₃
300	100	629
300	150	508
300	200	387
300	225	324
300	250	260
375	200	584
375	225	521
375	250	457
375	300	337
450	250	660
450	300	540
450	375	356
500	250	787
500	300	667
500	375	483
500	450	305

Nominal Size		
DN	dn	L ₃
600	300	934
600	375	749
600	450	572
600	500	444
750	375	1180
750	450	1000
750	500	885
750	600	645

SUREFLOW® FLANGED FITTINGS

DUCTILE IRON PIPELINE SYSTEMS

DUCKFOOT BENDS

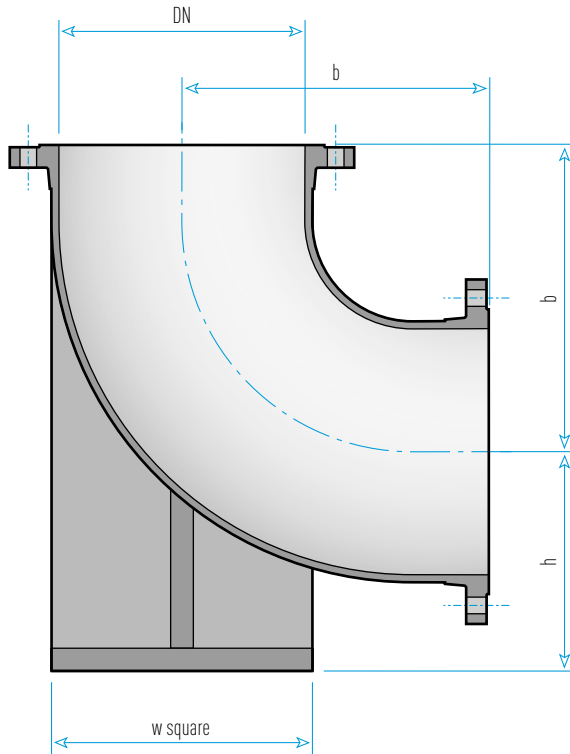

Nom Size	Dimensions		
DN	b	w	h
80	229	165	114
100	241	185	133
150	279	190	165
200	305	235	197
225	330	260	216
250	356	290	229
300	406	345	260
375	495	425	311
450	572	500	356
500	622	560	394
600	737	665	457

AUSLITE® fittings are highlighted in salmon

FLANGED BELLMOUTHS

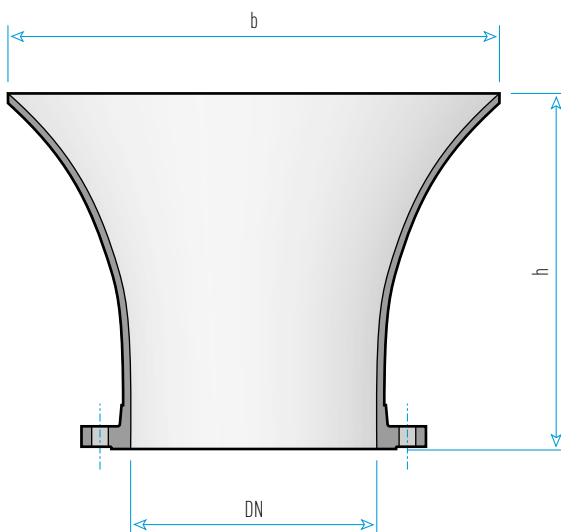

Nom Size	Dimensions	
DN	b	h
100	200	152
150	245	152
200	374	305
225	425	305
250	445	380
300	650	470
375	755	525
450	765	590
500	770	650
600	840	725
750	1250	845

SUREFLOW® FLANGED FITTINGS

DUCTILE IRON PIPELINE SYSTEMS

HYDRANT RISERS

Nom Size DN	L
80	100
80	150
80	225
80	300
80	375
80	450
80	600

Nom Size DN	L
100	100
100	150
100	225
100	300
100	375
100	450
100	500
100	600

AUSLITE Hydrant Risers - PN 16 only

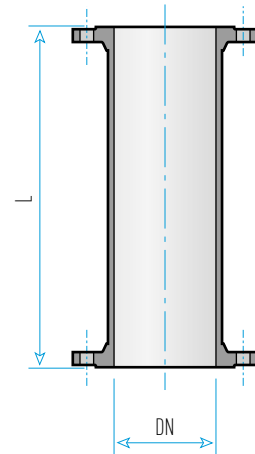

SYMBOL



THRUST FLANGES

Nom Size DN	Dimensions			Ultimate Shear Force kN
	d	t	L _{min}	
80	205	25	55	90
100	230	25	55	116
150	305	27	55	171
200	370	31	55	226
225	405	34	55	253
250	430	34	55	280
300	485	32	65	481
375	575	32	65	891
450	660	32	65	1061
500	730	35	70	1172
600	845	35	70	1397
750	1010	39	75	2881

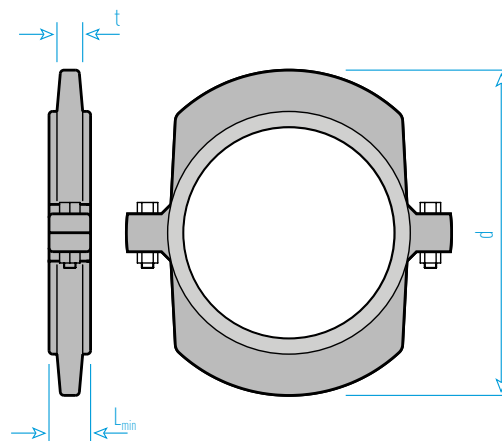

* The ultimate shear force is a theoretical value which assumes the mode of failure to be caused by shear of the circumferential pipe wall groove. The flange is assumed to remain bolted together and the shear area is calculated over a 45° circumferential plane with its root at the base of the pipe groove. Mating dimensions from AS/NZS 2280 are adopted.

Notes

1 It is recommended that puddle flanges are factory fitted onto pipes. AS/NZS 2280 calls for a machine groove to be cut into the outside surface of the pipe and the puddle flange machined accordingly to provide a nominal interference fit. An epoxy resin is utilised to prevent seepage along the outside surface of the pipe.

2 Lifting hole on DN 450 to DN 750 only.

SUREFLOW®

FLANGED FITTINGS

DUCTILE IRON PIPELINE SYSTEMS

INTEGRAL FLANGES

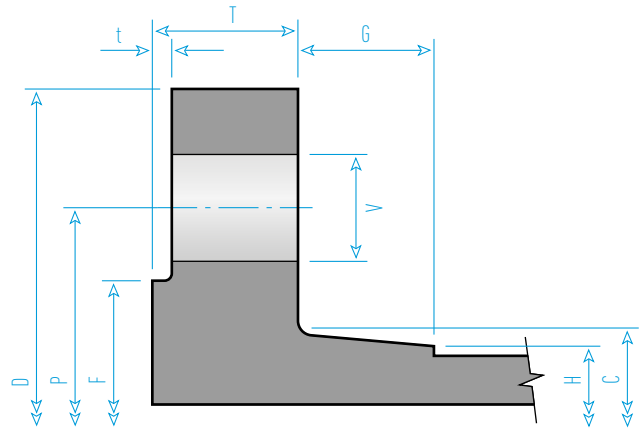

CLASS 16

Nominal Size DN	Flange Dimensions					Bolting Details (to AS 4087)			Neck Dimensions		
	Diameter D	Thickness T	Diameter of Raised Face F	Height of Raised Face t	Pitch Circle Diameter P	Number of Holes N	Diameter of Holes V	Fastener Size and Thread	Diameter of Large End C	Diameter of Small End H	Min Length of Taper G
80	185	18	122	3	146	4	18	M16	106	100	8
100	215	20	154	3	178	4	18	M16	136	126	11
150	280	23	211	3	235	8	18	M16	188	181	11
200	335	23	268	3	292	8	18	M16	243	236	12
225	370	24	300	3	324	8	18	M16	275	263	19
250	405	24	328	3	356	8	22	M20	307	290	26
300	455	30	378	4	406	12	22	M20	354	349	28
375	550	33	463	4	495	12	26	M24	439	430	30
450	640	33	552	4	584	12	26	M24	528	511	33
500	705	35	609	4	641	16	26	M24	581	564	34
600	825	42	720	5	756	16	30	M27	689	671	38
750	995	47	888	5	927	20	33	M30	855	830	53

CLASS 35

Nominal Size DN	Flange Dimensions					Bolting Details (to AS 4087)			Neck Dimensions		
	Diameter D	Thickness T	Diameter of Raised Face F	Height of Raised Face t	Pitch Circle Diameter P	Number of Holes N	Diameter of Holes V	Fastener Size and Thread	Diameter of Large End C	Diameter of Small End H	Min Length of Taper G
80	205	22	141	3	165	8	18	M16	110	100	11
100	230	22	167	3	191	8	18	M16	137	126	13
150	305	27	232	3	260	12	22	M20	198	181	20
200	370	31	296	3	324	12	22	M20	257	236	27
225	405	34	324	3	356	12	26	M24	290	263	33
250	430	34	349	3	381	12	26	M24	315	290	33
300	490	38	406	4	438	16	26	M24	376	349	38
375	580	42	485	4	521	16	30	M27	459	430	42
450	675	46	571	4	610	20	33	M30	542	511	48
500	735	49	634	4	673	24	33	M30	602	564	60
600	850	54	739	5	781	24	36	M33	710	671	66
750	1015	59	898	5	940	28	36	M33	870	830	73

SUREFLOW® FLANGED FITTINGS

DUCTILE IRON PIPELINE SYSTEMS

TYPICAL SPECIFYING SEQUENCES

Specifying a high pressure DN 150 fusion coated flanged tee with a DN 100 branch

Example	150x150-100	-	FL-FLxFL	TEE	HPFC
Nominal Size					
Angle (if applicable)					
End Type/s - FL: Flange, SC: Socket, SP: Spigot					
Type of Fitting - TEE, BEND, TAPER, CONN					
Extra Information - TC: Figure B5 Flange, HP: Figure B6 Flange, CL: Cement Lined, FC: Fusion Coated					

Specifying a 22.5 degree standard pressure DN 100 cement lined, bitumen coated bend

Example	100	22½	FL-FL	BEND	TCCL
Nominal Size					
Angle (if applicable)					
End Type/s - FL: Flange, SC: Socket, SP: Spigot					
Type of Fitting - TEE, BEND, TAPER, CONN					
Extra Information - TC: Figure B5 Flange, HP: Figure B6 Flange, CL: Cement Lined, FC: Fusion Coated					

ADELAIDE
P: 08 8340 3411
F: 08 8340 3422
E: ccasales@viadux.com.au

BRISBANE
P: 07 5589 4400
F: 07 5534 7079
E: ccbsales@viadux.com.au

DARWIN
P: 08 8935 3300
F: 08 8947 3981
E: ccbsales@viadux.com.au

GOLD COAST
P: 07 5589 4400
F: 07 5534 7079
E: ccgsales@viadux.com.au

MELBOURNE
P: 03 9309 9133
F: 03 9309 6237
E: ccmsales@viadux.com.au

PERTH
P: 08 9346 8500
F: 08 9346 8501
E: ccpsales@viadux.com.au

SYDNEY
P: 02 9794 3440
F: 02 9794 3499
E: ccssales@viadux.com.au

TOWNSVILLE
P: 07 4725 5940
F: 07 4725 4995
E: cctsales@viadux.com.au

VIADUX PTY LTD PO BOX 141 FAIRFIELD, NEW SOUTH WALES 1860 AUSTRALIA / VIADUX.COM.AU / PHONE 1300VIADUX

All Viadux trademarks and logos are owned by Viadux Pty Ltd. All other brand or product names are trademarks or registered marks of their respective owners. Because we are continuously improving our products and services, Viadux reserves the right to change specifications without prior notice. FF1606